

Browning[®]

Belt Drives & Bearings Reference Guide

- Product Information
- Installation
- Preventative Maintenance
- Troubleshooting



EMERSON[™]

Browning®

V-Belts

Unique design enhances performance and provides increased HP capacity in shorter center drives.

FHP



3L
3/8"



4L
1/2"



5L
21/32"

CLASICAL



"A" Belts
1/2" x 5/16"



"B" Belts
21/32" x 7/16"



"C" Belts
7/8" x 17/32"

358



3V
3/8" x 5/16"



5V
5/8" x 17/32"

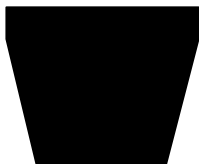

8V
1" x 29/32"

Index	Page
Save the Green.....	2 - 3
Belts.....	4 - 76
Sheaves.....	77 - 98
Split Taper Bushing.....	99
Bearings	100 - 117
Visit our online resources	118



V-Belt Drives and Bearings

Electronic Tools for the HVAC Industry

- eCatalog
- Smart Interchange
- Emerson Power Transmission Edge product selection



Save the Green®

Energy Responsibility In Three Easy Steps

- 1** *Upgrade from wrapped to notched belts and improve efficiency.*
- 2** *Worn sheaves allow belt slip. Inspect sheaves for wear. Wear greater than 1/32" can decrease efficiency 5% or more.*
- 3** *Properly tension belts.*

Upgrade from wrapped to notched belts and improve efficiency

Save the Green®

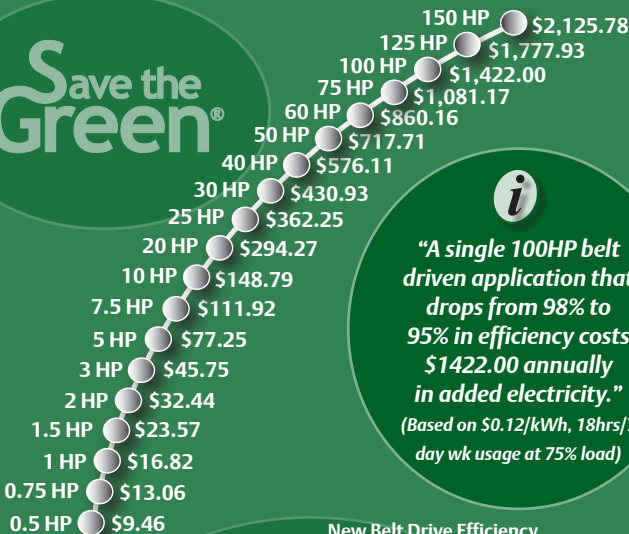

“A single 100HP belt driven application that drops from 98% to 95% in efficiency costs \$1422.00 annually in added electricity.”

(Based on \$0.12/kWh, 18hrs/7 day wk usage at 75% load)

New Belt Drive Efficiency Calculator * Patent Pending at www.emerson-ept.com



Check out our new video “Save the Green – Energy responsibility in three easy steps” at www.emerson-ept.com or visit us on YouTube at channel “ThePowerTransmission”



It's free. Download the Browning® Energy Efficiency Calculator for your iPhone, Droid or BlackBerry. Search “Browning vbelts”



Belts & Sheaves

Technology Leadership to Meet Drive Requirements with Shorter Center Distance and Higher Speeds

Browning®

VP Vortex Variable Speed Sheaves

Engineered Features

- External rib design provides cooling for longer belt life
- Increases wall thickness by 30%
- Increased hub diameter by 20%
- Tighter tolerances by 25%
- Balanced as components
- Twice balanced after assembly
- Larger MVP® sheaves dynamically balanced in two planes
- Tightened micro-finish on groove walls for increased belt life
- Now accommodates 5VX belts



Variable Pitch
Cast Iron
Sheaves

Browning® Brand V-Belts

Engineered Features

- Special blend of fiberglass and polyester for belt cord flexibility and strength
- Length tolerances 10X tighter than industry standard
- Single belt fabric with no overlap for reduced vibration
- Tubular woven fabric for lengthwise flexibility and cross rigidity
- Ground form edges on AX, BX, 3VX and 5VX belts for reduced vibration



Super
Gripbelt®



"358" Gripbelt®

Emerson Power Transmission Edge® — your online support for V-Drive and bearing selection.

Edge online tools include: eCatalog, product selection, CAD templates, Smart Interchange, product literature and engineered solutions. Available at www.emerson-ept.com.

Index

Page

V-Belt Advantages & Construction 6 - 7

Section 1 - Preventive Maintenance and 8 - 14
Installation of V-Belt Drives

Section 2 - Corrective Maintenance and 15 - 59
Troubleshooting of V-Belt Drives

A - Troubleshooting Installation Problems 18 - 24

B - Troubleshooting Selection Problems 25 - 28

C - Troubleshooting Environmental Problems 29 - 32

D - Troubleshooting Design Problems 33 - 37

E - Design and Installation Suggestions 38 - 41

F - Gripbelt® Drive Engineering Data 42 - 59

Belts

Super Gripbelt® Belts 62 - 65

Gripnotch™ Belts 66 - 69

FHP Belts 70 - 73

358 Gripbelts 74

Belts Cross Reference 75 - 76

Sheaves

AK Sheaves 78 - 79

2AK Sheaves 80 - 81

AKH Sheaves 82

2AKH Sheaves 83

BK Sheaves 84 - 85

2BK Sheaves 86

BKH Sheaves 87

2BKH Sheaves 88

Stock Sheave Interchange 89

B5V® Sheaves 90 - 93

1VP Sheaves 94 - 95

2VP Sheaves 96 - 97

VL, VM Sheaves 98

Split Taper Bushings 99

Visit our online resources 118

V-Belt Drive Advantages

V-belt drives provide many maintenance advantages that help in your daily struggle to reduce equipment repairs and to hold forced downtime to the lowest possible level.

1. They are rugged—they will give years of trouble-free performance when given just reasonable attention...even under adverse conditions.
2. They are clean—require no lubrication.
3. They are efficient—performing with an average of 94-98% efficiency.
4. They are smooth starting and running.
5. They cover extremely wide horsepower ranges.
6. They permit a wide range of driven speeds, using standard electric motors.
7. They dampen vibration between driving and driven machines.
8. They are quiet.
9. They act as a “safety fuse” in the power drive because they refuse to transmit a severe overload of power, except for a very brief time.
10. V-belts and sheaves **wear gradually**—making preventive corrective maintenance simple and easy.

V-Belt Construction

Unique design enhances performance provides increased HP capacity in shorter center drives.

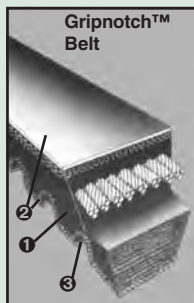
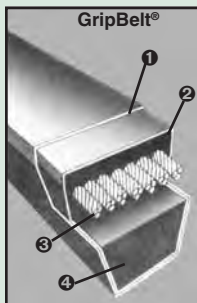

Before we talk about “*Avoiding Problems*” and “*Solving Problems*” let’s take a brief look at how V-belts are constructed.

There are basically two types of construction. One has a fabric wrapper (or jacket) surrounding it; the other – usually rated higher in horsepower – is made in a raw edged, coggled construction.

GripBelt®

- 1. Single Fabric Design**
 - More flexible - use with subminimal pitch diameters.
 - Reduced overlap - reduces vibration
- 2. Improved Cord Adhesion**
- 3. Improved flexibility cords**
- 4. Improved SBR compounds**

Gripnotch™ V-Belts

- 1. Ground Form**
 - Reduces vibration, increases belt and bearing life.
- 2. Fabric Top and Bottom**
 - Increases rigidity and stability. Reduces stress on the cord line, increases belt life.
- 3. Wider Notch Spacing**
 - Increases rigidity and stability. Reduces stress on the cord line increases belt life.

Preventive Maintenance and Installation of V-Belt Drives

⚠ WARNING

- Read and follow all instructions carefully.
- Disconnect and lock-out power before installation and maintenance. Working on or near energized equipment can result in severe injury or death.
- Do not operate equipment without guards in place. Exposed equipment can result in severe injury or death.

⚠ CAUTION

- Periodic inspections should be performed. Failure to perform proper maintenance can result in premature product failure and personal injury.

You will notice **reference key numbers** (such as **A-1**) appear throughout this section. These refer to a more detailed discussion with illustrations relating to the subject in Section 2 (Corrective Maintenance and Troubleshooting).

Preventive Maintenance and Installation of V-Belt Drives

1. Safety First

Before doing any maintenance work on power drives, **be sure the controlling switch is in the off position—and locked if possible. Follow your plant's safety rules.**

2. Select Replacement Belts

B-1, B-2, B-3, B-4

After you have made any necessary corrections in your V-belt drive elements, the next step is the selection of the correct replacement belts.

When replacing sets of V-belts, here are some **very important reminders:**

- Never mix new and used belts on a drive.
- Never mix belts from more than one manufacturer.
- Always replace with the right type of V-belt.
- Always observe V-belt matching limits.

3. Remove Belt Guard

A-1

Clean and inspect belt guard thoroughly. After removing the drive guard, loosen the drive take-up and move the sheaves closer together to facilitate the removal of any old belts, and to ensure installation of the new belts without damage.



Preventive Maintenance and Installation of V-Belt Drives

4. Inspect Drive Elements

A-1, A-6

This is a good time to service the take-up rails by removing any rust, debris, or dirt. Lubricate the bearings as necessary so tensioning of the new belts will go smoothly and easily. This is also an excellent opportunity to inspect and replace faulty or damaged machine elements such as worn bearings and bent shafts.

These maintenance procedures not only reduce the likelihood of future mechanical trouble, but also ensure maximum service from the new belts.

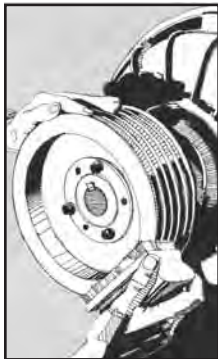

Preventive Maintenance and Installation of V-Belt Drives

5. Inspect Sheaves

A-4, A-9

Sheave condition and alignment are vital to V-belt life and performance. **New V-belts should never be installed without a careful and thorough inspection of the sheaves involved.**

Particular attention should be given to these conditions.

Replace sheaves if worn:

- a. Worn groove sidewalls
- b. Shiny sheave groove bottom
- c. Wobbling sheaves
- d. Damaged sheaves

Sheaves should be carefully cleaned of any rust and foreign material. A wire brush followed up by wiping with a shop cloth will usually do the job.



Worn Groove Sidewalls

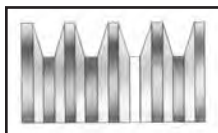

Shiny Sheave Groove Bottom

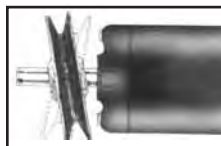

Wobbling Sheaves

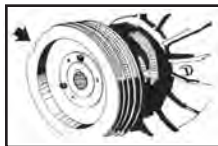

Damaged Sheaves



Groove Gage

Preventive Maintenance and Installation of V-Belt Drives

6. Check Sheave Alignment

A-3

One of the great advantages of V-belt drives is the fact that perfect alignment of sheaves is not critical to the operation of the drive. However, the better the alignment, the better the performance.

Refer to Section 2, A-3, for information on proper alignment procedures and tolerances.

Note: Sheaves should always be mounted as close to the bearings as practical to avoid excessive loads on bearings and shafts.

7. Installing New Belts

A-1

Place the new belts on the sheaves, and be sure that the slack of each belt is on the same side. You can do this by pressing the belts with your hand to bring the slack on one side of the drive. Loosening the drive take-up in advance makes this easy.

Do not force the belts on the sheaves by using a pry bar or by rolling the sheaves. Move sheaves apart until the belts are seated in the grooves. Tighten drive until slack is taken up. (Tensioning suggestions follow in Step 8).

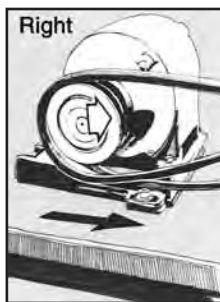

Preventive Maintenance and Installation of V-Belt Drives

8. Apply Tension

A-7, A-8

All V-belt drives must operate under proper tension to produce the wedging action of the belt against the groove sidewall. A well-established rule of thumb is that the best tension for a V-belt drive is the LEAST tension at which the drive will not slip under peak load.

Browning recommends using a belt tension checker to properly tension belts.



9. Recheck Sheave Alignment

A-3

Anytime sheaves have moved, recheck sheave alignment.

Refer to Section 2, A-3, for information on proper alignment procedures and tolerances.

10. Replace Guard

Start drive. (Look and listen) Check tension after 8, 24 and 100 hours and periodically thereafter.

11. Start Drive

A-7

Properly designed V-belt drives should not squeal under peak load conditions. If necessary, stop the drive, then start it again. If a squeal is heard, the belts should be tightened to the point where they do not squeal under peak load. Newly installed belts require about 24 hours to become fully seated in the groove.

Re-tension after 3 minutes, 8 hours, 24 hours, 100 hours, and periodically thereafter.

Preventive Maintenance and Installation of V-Belt Drives**V-Belt Installation Check List**

- 1. Turn off and lock out power source
Observe all other safety procedures
- 2. Select proper replacement belts
- 3. Remove belt guard
- 4. Inspect drive elements—bearings, shaft, etc.
- 5. Inspect sheave grooves for wear
- 6. Check sheave alignment
- 7. Install new belts
- 8. Tension belts
- 9. Check sheave alignment (final)
- 10. Replace guard
- 11. Start drive (look & listen)

Corrective Maintenance and Troubleshooting of V-Belt Drives

⚠ WARNING

- Read and follow all instructions carefully.
- Disconnect and lock-out power before installation and maintenance. Working on or near energized equipment can result in severe injury or death.
- Do not operate equipment without guards in place. Exposed equipment can result in severe injury or death.

⚠ CAUTION

- Periodic inspections should be performed. Failure to perform proper maintenance can result in premature product failure and personal injury.

The first section of this HVAC Pocket Reference Guide outlined a step-by-step procedure for the installation of replacement V-belts to help you prevent V-belt maintenance problems.

The reason behind these steps is **also** fundamental in the daily inspection and maintenance of V-belt drives. **Watching** and **listening** will alert you to warning signs of trouble, since one of the greatest advantages of V-belt drives is the fact that belts and sheaves **wear gradually**. You can spot potential problems in time to arrange short, **scheduled** maintenance downtime instead of experiencing a longer, costly interruption of production when unexpected trouble occurs.

You can compare V-belts to an electrical fuse – their unexpected failure is usually a signal that something **else** in the system is wrong. Even their patterns of gradual wear often indicate conditions needing corrections or improvements.

Corrective Maintenance and Troubleshooting of V-Belt Drives

CURES	A-1	A-2	A-3	A-4	A-5
CAUSES	Belts Pried On or Misplaced Slack	Belts Rubbing Guard	Sheaves Misaligned	Worn or Damaged Sheaves	Sheaves Too Far From Bearing
SYMPTOMS					
Rapid Sidewall Wear		●	●	●	
Worn Cover on Back	●				
Belt Turns Over Or Jumps Off Sheave	●				
Belt Soft, Swollen					
Belt Slips, Squeals (Spin Burn)				●	
Belt Cover Split	●				
Underside Cracked			●		
Tie-Band Damaged		●	●	●	
Repeated Breakage	●				
Belts Ride Too High					
Belts Bottoming				●	
Repeated Take-up Necessary				●	
Belts Vibrate Excessively or Appear Mismatched			●	●	
Bearing Are Hot				●	●
Shafts Whip or Bend				●	●
Cracked Bushings				●	
Sheave Wobble				●	

● Indicates most common causes

Corrective Maintenance and Troubleshooting of V-Belt Drives

A-6	Poor Bearing or Shaft Condition																			
A-7	Insufficient Tension	●				●														
A-8	Excessive Tension																			
A-9	Improper Sheave Installation																			
B-1	Belts Worn (Normal Service Life)						●													
B-2	Wrong Belt Cross-Section or Type	●					●													
B-3	Mismatched Belts or Mixed Brands																			
B-4	Machine-Induces Impulse or Shock						●													
C-1	Improper or Prolonged Storage	●					●													
C-2	Excessive heat	●																		
C-3	Excessive Oil or Grease	●							●											
C-4	Use of Belt Dressing	●							●											
C-5	Abrasive Environment	●																		
C-6	Foreign Objects in Grooves									●										
C-7	Excessive Moisture	●								●										
D-1	Overloaded Drive Underbelting									●										
D-2	Drive Seriously Overbelted														●					
D-3	Sheaves Too Small													●						
D-4	Insufficient Wrap on Small Sheave																		●	
D-5	Backside Idler																			●

Troubleshooting Installation Problems

⚠ WARNING

- Read and follow all instructions carefully.
- Disconnect and lock-out power before installation and maintenance. Working on or near energized equipment can result in severe injury or death.
- Do not operate equipment without guards in place. Exposed equipment can result in severe injury or death.

⚠ CAUTION

- Periodic inspections should be performed. Failure to perform proper maintenance can result in premature product failure and personal injury.

As pointed out in Section 1 of this manual, preventive maintenance by using proper installation techniques is important for long, trouble-free V-belt service.

Occasionally, however, you will find it necessary to correct problems caused by improper installation. This section deals with these problems and troubleshooting procedures.

Troubleshooting Installation Problems

A-1 Prying or forcing V-belts onto the sheaves

can, and usually does, break some of the load-carrying tensile cords (see illustration on page 10, Section A-1). When this happens, the belt may either break or turn over in the groove, usually within the first few minutes of operation. This method of installation may be evidenced by a rupture or split in the wrapped cover of the belt, caused by the prying tool or sheave edge. Broken cords are easily identifiable on raw-edge V-belts because it is usually the edge cords that break first.

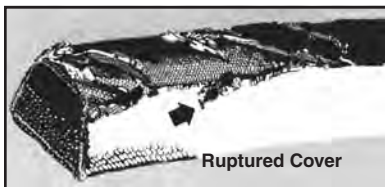

A-2 Belts rubbing against the metal guard

or other obstruction will be evidenced by cut or worn fabric on the back or upper edge of the V-belt. Often just replacing missing bolts in guard brackets will remedy this situation.



Misplaced slack can also cause belt breakage, again usually on startup. This occurs on multiple-belt drives when all of the belt slack is not brought to the same side of the drive before tensioning. If some belts are tight on one side, and others are tight on the other side, the heavy shock load of starting will be borne by only some of the belts, thus weakening or breaking the load-carrying cords.

Troubleshooting Installation Problems

A-3 Misaligned sheaves

can cause rapid wear of the V-belt sidewalls, considerably shortening service life of both belts and sheaves. Misalignment can also cause separation of the tie-band on banded belts, or apparent mismatching of individual belts. V-belt sheave alignment should be within a tolerance of **1/2° on notched belts and ±2° on wrapped belts**.

The three basic types of sheave and shaft misalignment are shown below. Suggested methods for checking and correcting each type are found on page 19.

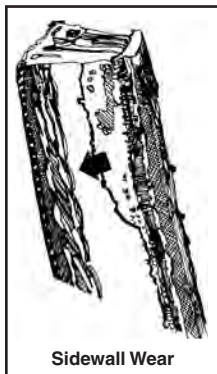

Note: All three types may be present at the same time. Alignment should be checked and corrected in the order given.

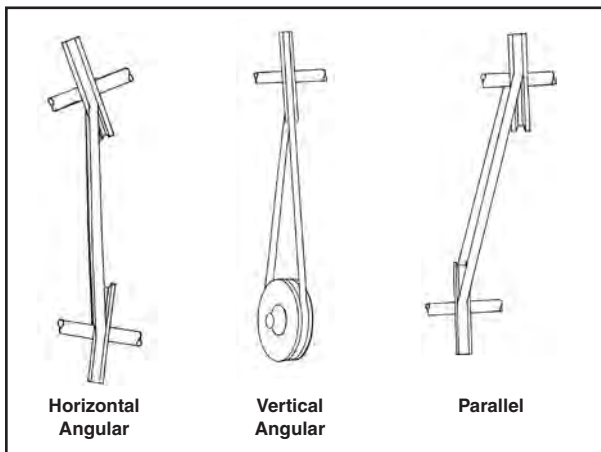

Troubleshooting Installation Problems

- 1. Horizontal Angular** (shafts in same horizontal plane but not parallel)

To Check: Use straightedge or string near sheave centers.

To Correct: Loosen motor mounting bolts and rotate motor until all four points touch straightedge.

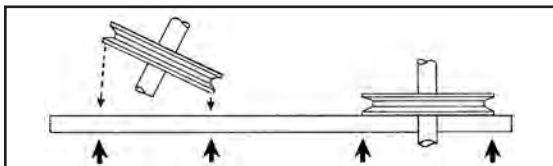

- 2. Vertical Angular** (shafts not in the same plane and not parallel)

To Check: Place straightedge about 1/4 radius from the outside diameter of both sheaves as shown. Repeat on opposite side of shaft 2. Straightedge should touch four points indicated in each position.

To Correct: Use shims under motor base in front or rear of motor, depending on type of correction required.

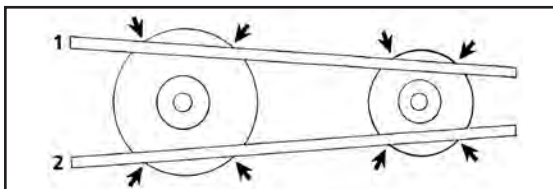

- 3. Parallel** (shafts are parallel; sheaves not in line)

To Check: Use straightedge or string near sheave centers.

To Correct: Loosen sheave so it slides easily on shaft until all four points touch straightedge. Retighten sheave in position. Important: Sheave should be mounted as close to bearing as possible to reduce overhung load on bearing. Relocate equipment if necessary.

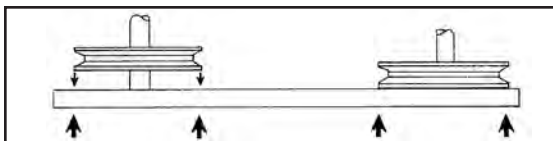

Troubleshooting Installation Problems

A-4 Worn or damaged sheaves are an even greater cause of rapid belt wear, slippage and vibration. Badly worn sheaves can cause over-tensioning of the drive to prevent slippage, indirectly causing over-heated bearings and shaft damage. If pieces of the sheave flange are missing, it will result in badly worn sidewalls of the belt, and the resulting sheave imbalance can damage bearings and create a safety hazard. When only some of the grooves are worn more than others, the effect is that the belts **appear** to be mismatched. It also causes “differential driving,” where only some of the belts are carrying the entire load of the drive.

In the case of banded belts, worn grooves cause the belts to ride too low in the grooves, thus causing the tie-band to wear against the sheave flanges between the grooves. In severe cases, this can have the same effect as a circular blade, cutting the band and separating the belts.

Sheave templates are available from your distributor, which can be used to check grooves accurately for wear. A flashlight held behind the template when placed in the groove will help you to observe the amount of wear. “Dishing” should not exceed 1/32”

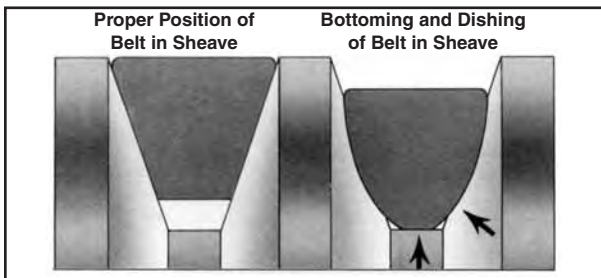
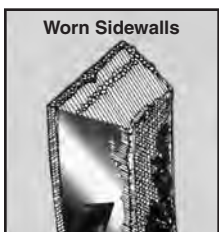

Troubleshooting Installation Problems

for individual sheave sidewalls. A shiny groove bottom is a sign that the belt or sheave, or both are badly worn and the belt is bottoming in the groove. Worn sheaves or shiny sheave groove bottoms will show up first on the smaller sheave.

The cost of replacing a worn sheave will be more than recovered in longer V-belt life, reduced maintenance and downtime.

A-5 Sheaves mounted too far from the bearing cause excessive overhung load on the bearing and overheating. This can also cause shafting to whip, bend or break. Sheaves should be mounted as close as possible to the bearing. If this affects alignment severely, it may be necessary to relocate the equipment to stay within alignment limits of 1/16" per 12" of shaft center-to-center distance.

A-6 Bearing condition and normal wear may well be the cause of overheating, rather than belt tension. They should be inspected for proper lubrication and wear according to the specifications of the bearing or equipment manufacturer. **Shaft condition** should also be checked and replaced if necessary, as bent shafts can be detrimental to bearings, belts and sheaves, as well as being a safety hazard due to the imbalance created. Sheave "wobble" may be caused by bent shafts.

A-7 Insufficient belt tension it's the leading cause of V-belt slippage and premature belt failure. This is often evidenced by "spin burn". The easiest and most practical way for maintenance personnel to judge proper belt tension is by use of a Browning belt tension checker.

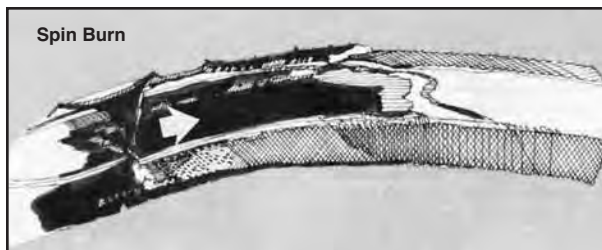

Troubleshooting Installation Problems

A-8 Excessive tension on V-belts can be even more detrimental than too little tension, affecting not only the belts, but also bearings and shafts. Again, the best rule is to apply only enough tension on the belts to keep them from slipping during startup or peak loading. Some indicators of excessive tensioning (but not always) are:

- Repeated belt breakage
- Excessive vibration
- Overheated bearings
- Whipping or bent shafts

A-9 Improper sheave and bushing installation can result in sheave “wobble” as well as causing sheave hubs to crack. When installing split-tapered bushings always follow manufacturer’s instructions.

It is important to **never** lubricate the tapered surfaces before installing. The lubrication will permit recommended torque wrench values to increase the actual force on the bushing and hub. This usually results in cracking of the hub at the bolt hole or keyway.

On flanged bushing types, proper installation should result in a gap between the bushing flange and the hub face. The absence of a gap may indicate a problem. When removing split-tapered bushings, start at the jack-screw hole opposite the split to avoid cracking the bushing.

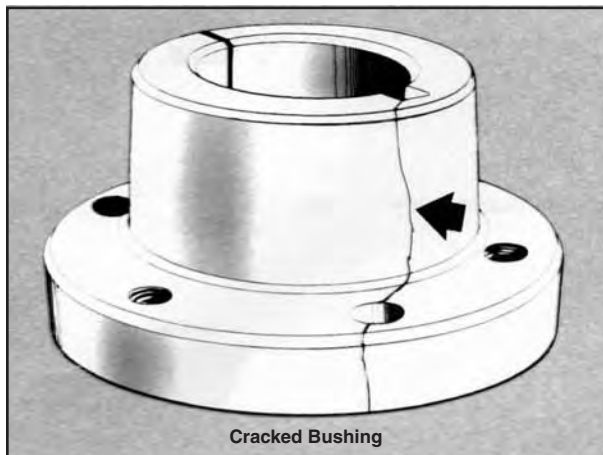

Troubleshooting Selection Problems**⚠ WARNING**

- Read and follow all instructions carefully.
- Disconnect and lock-out power before installation and maintenance. Working on or near energized equipment can result in severe injury or death.
- Do not operate equipment without guards in place. Exposed equipment can result in severe injury or death.

⚠ CAUTION

- Periodic inspections should be performed. Failure to perform proper maintenance can result in premature product failure and personal injury.

The array of V-belt types, cross-sections and lengths on the market today are all part of technological efforts to provide more efficient, cost-saving answers to your drive requirements.

This category is intended to point out how you can be sure of applying the best V-belt type to your applications.

Troubleshooting Selection Problems

B-1 Worn V-belts may have gotten that way simply because they have delivered the service life built into them. Browning, strives to design V-belts with a “balanced” construction, so each element of the belt will last as long as all other elements. But the wide variety of industrial applications, environmental conditions and maintenance practices makes this impossible to achieve. However, the expected life of an industrial V-belt on a properly designed and maintained drive is three to five years.

B-2 Using the wrong V-belt cross-section or type can create problems for you...and it's not hard to do, since many belts have similar dimensions. For example, the following V-belts have approximately the same top width (5/8") and length (85" outside circumference).

And yet, the horsepower ratings of these belts range from as little as 2.2 HP per belt to as much as 11.9 HP per belt on a 5" diameter sheave and a 1750 RPM motor!

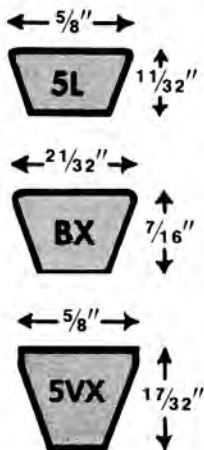

Troubleshooting Selection Problems

B-3 Mismatched belts or mixed brands from different manufacturers **should not** be matched together, and will **not** deliver the expected service life.

Although all manufacturers use similar belt numbering systems, different brands with the same number will differ slightly in dimensions and are not capable of being mixed in a set. Also, construction differences cause them to ride differently in the grooves, and to stretch differently.

It should be noted that the majority of complaints regarding belt matching are due to other causes, such as misalignment and sheave wear. These factors should always be checked if belts seem to be mismatched.

B-4 Machine-induced vibration or shock loads frequently can cause V-belts to whip or even jump off the drive, creating a safety hazard, and of course, damaging the belts.

On multiple-belt drives, this whipping can be reduced or eliminated by using banded V-belts. A banded V-belt consists of from two to five individual V-belts joined together with a bonded, reinforced tie-band (see illustration).

These belts ride slightly higher in the sheave grooves to provide clearance between the band and the sheave flange. Because of this, sheave grooves should not be worn or “dished-out” more than 1/64". Also, because the belts are banded together, alignment of the sheaves is more critical.

(The chart on the next page will be helpful in selecting the best belt for an application.)

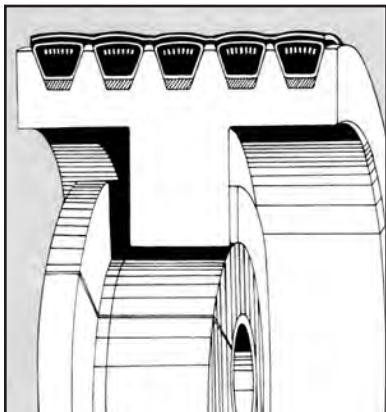

Troubleshooting Selection Problems

V-Belt Selection Guide

Generic Belt Type (Cross Sections)	Normal HP Range	maximum Belt Speed (FT/Min)(1)	Normal Temp. Range (°F)		Oil/Heat Resistance	Static Dissipating	General Application
			min.	Max.			
Super Gripbelt® (A, B, C, D)	1-500	6,500	-35	40	Good	✓	General-Purpose Heavy Duty Industrial Drives
Gripnotch™ Multiple (AX, BX, CX)	1-500	6,500	-35	140	Excellent	✓	Longer Life, High Efficiency, Small Diameters
358 Gripbelts (3V, 5V, 8V)	1-1000	6,500	-35	140	Very Good	✓	High-Performance, Compact Industrial Drives, Long C.D.
358 Gripnotch (3VX, 5VX)	1-600	6,500	-35	140	Excellent	✓	High-Performance, Compact Industrial Drives, Short C.D.
Double-V Belts (AA, BB, CC, DD)	1-200	6,500	-35	140	Good	Special Order	Serpentine Drives
FHP (2L, 3L, 4L, 5L)	Light Duty	6,500	-35	140	Fair	Special Order	Light Duty Drives Using a Single Belt

Notes: (1) Normally limited by sheave materials.

Troubleshooting Environmental Problems**⚠ WARNING**

- Read and follow all instructions carefully.
- Disconnect and lock-out power before installation and maintenance. Working on or near energized equipment can result in severe injury or death.
- Do not operate equipment without guards in place. Exposed equipment can result in severe injury or death.

⚠ CAUTION

- Periodic inspections should be performed. Failure to perform proper maintenance can result in premature product failure and personal injury.

“Environmental Protection” can be as important for a V-belt as for humans. This section deals with the effect of adverse environmental conditions on V-belts and how you can minimize these effects.

Troubleshooting Environmental Problems

C-1 Improper or prolonged storage can reduce service life considerably. V-belts should be stored in a cool, dry place with no direct sunlight. On shelves, in boxes or piles, the stack should be small enough to avoid excess weight and distortion on the bottom belts. On pegs, the longer belts should be coiled in loops of suitable size to prevent distortion from the weight of the belt.

The following guide provided by the RMA should be followed for optimum conditions:

Guide to Maximum Number of Coilings of V-Belts of Storage

Belt Cross Section	Belt Length (Inches)	Number of Coilings*	Number of Loops*
A, AA, "3V and B	Under 60.0	None	1
	60.0 to 120.0	1	3
	120.0 to 180.0	2	5
	180.0 and up	3	7
BB, "C, and 5V	Under 75.0	None	1
	75.0 to 144.0	1	3
	144.0 to 240.0	2	5
	240.0 and up	3	7
D	Under 120.0	None	1
	120.0 to 240.0	1	3
	240.0 to 330.0	2	5
	330.0 to 420.0	3	7
	420.0 and up	4	9
E and 8V	Under 180.0	None	1
	180.0 to 270.0	1	3
	270.0 to 390.0	2	5
	390.0 to 480.0	3	7
	480.0 and up	4	9

*One coiling results in three loops; two coilings result in five loops, etc.

**"AA" and "BB" are known as "double angle" or "hexagonal" V-belts.

The pegs should be crescent shaped in cross-section to avoid compression set dents in the belts from sharp corners and the pegs should be sufficiently large in cross-section to avoid compression setting to sharp bends resulting from the weight of the hanging belts.

It is recognized that belts are sometimes coiled in smaller loops than indicated in the above table, for packaging for shipment, but such packaging should not be for prolonged storage.

Troubleshooting Environmental Problems

C-2 Excessive heat. Standard construction V-belts are compounded for moderate heat resistance and should give adequate service under normal conditions.

Belt temperature (not ambient or surrounding air temperature) is the determining factor when heat is a suspected cause of short belt life.

As a general rule service life of a V-belt is cut in half for every 35°F raise in belt temperature above 85°F.

Evidence of heat may be the appearance of small cracks on the underside of the belt.

What to do about excessive heat:

1. Check for slippage (see key number A-7)
2. Ventilate the drive or shield from heat source
3. Check to make sure the proper belt size is installed
4. Check the horsepower capacity of the drive



C-3 Excessive oil or grease. Standard construction V-belts

are compounded for moderate grease and oil resistance. However, an excessive amount can cause softening, swelling and deterioration of the rubber compounds, as well as slippage.

What to do about oil or grease:

1. When there is occasional exposure from spillage or leakage, the belts and sheave grooves should be cleaned with a mixture of detergent and water—**after the drive has been turned off and locked out** and the cause of the leakage corrected.
2. When belts cannot be protected from oil, specially compounded oil-resistant V-belts should be used.

Troubleshooting Environmental Problems

C-4 Never apply so-called “belt dressings” to V-belts. These compounds are usually made from a petroleum derivative and can have a destructive effect on rubber compounds and other components of the belt. If belts slip, check for adequate tension and/or worn sheave grooves (see **A-4**, **A-7**).



C-5 Abrasive conditions from sand, dust or grit can accelerate wear of both belts and sheaves. This is especially true when slippage is present. Belt selection can be an important factor. Experience has shown that raw-edge constructions reduce this wear because they reduce the “sandpaper-effect” caused by slippage. Drive should be well-shielded against excessive abrasive particles as much as possible.



C-6 Foreign objects, such as wood chips, can create havoc with V-belt drives. Belt breakage and turnover are the most common symptoms. Shielding the drive is a necessity. Belt guards with expanded metal screening are often used, but ventilation is sometimes sacrificed, possibly requiring additional induced cooling. Banding belts are often effective, since they eliminate belt turnover.

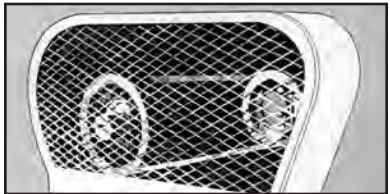

C-7 Excessive moisture can penetrate the fabric covering of a V-belt, causing deterioration. In addition, a large amount of water can reduce friction and cause slippage. Belt drives should be protected as much as possible when used outside or when subject to spray from washdown hoses, etc. Belt tension should be inspected regularly.

Troubleshooting Design Problems

⚠ WARNING

- Read and follow all instructions carefully.
- Disconnect and lock-out power before installation and maintenance. Working on or near energized equipment can result in severe injury or death.
- Do not operate equipment without guards in place. Exposed equipment can result in severe injury or death.

⚠ CAUTION

- Periodic inspections should be performed. Failure to perform proper maintenance can result in premature product failure and personal injury.

When normal corrective measures, as presented in the previous sections, do not seem to produce the desired results, an inherent design problem may be the culprit. The solutions to these are best left up to the Browning Application Engineering Department or a Certified Drive Specialist. However, the discussion presented in this section will help identify symptoms caused by design problems.

Troubleshooting Design Problems

D-1 Underbelting a drive, (using fewer belts than recommended by good design practice) results in excessive tension in each belt on the drive.

This is commonly evidenced by excessive stretching which requires frequent take-ups to prevent slippage. Another warning sign can be repeated belt breakage.

In many cases, underbelting can be corrected simply by using raw edge, cogged V-belts which have a higher horsepower rating. When these are used, drives should be identified to assure that future replacements are made with this type of belt. (Drive labels are available for this purpose.)

D-2 Drive overbelting, while usually resulting in longer V-belt life, can be just as serious as underbelting. The symptoms most commonly found are overheated bearings and bent shafts. This is especially true if belt tensioning devices are used without regard to design factors.

These devices, called tension-checkers, are quite helpful in determining proper belt tension, but tension values taken from published tables do not apply to all drives. Therefore, when these devices are used the deflection force values should be calculated, rather than taken from such tables. Contact Browning Application Engineering, 800-626-2093, for proper tensioning values.

Tensioning devices measure the *individual* belt tensions; so, when too many belts are on the drive, the *total* tension can be excessive when “table” values are used. On the other hand, when too few belts are on the drive, tension values from these tables may be inadequate.

Most design handbooks contain the formulas and procedures for making these simple calculations.

Another not-so-common symptom is belt vibration, resulting from tension harmonics. Since induced vibration can be caused by several factors, this should be referred to Browning Application Engineering.



Troubleshooting Design Problems

D-3 When sheaves are too small for the belt cross-section, the belt flexes beyond its normal limits. This is usually evidenced by cracks on the underside of the belt. Table A indicates the minimum recommended sheave diameter for flexing each belt cross-section. In most cases, use of a raw-edge cogged belt will improve service life greatly, due to its greater flexibility.

Table A. Minimum Recommended Sheave and Idler Diameters.

V-Belt Cross Section	Minimum P.D. Sheave or Inside Idler	Minimum O.D. Flat Backside Idler*
A	3.0	4.5
B	5.0	7.5
C	9.0	13.5
D	13.0	19.5
E	21.0	31.5
AX	2.6	4.0
BX	4.0	6.0
CX	7.0	10.5
3V	2.6	-
5V	7.0	-
5VX	4.3	-
8V	12.4	-
8VX	11.2	-

*Note: Backside idlers are detrimental to V-belt service life.

Another problem caused by sheaves that are too small is overheating of motor bearings, or even bent shafts. NEMA publishes minimum recommended sheave diameters for use with electric motors to avoid excessive bearing loads. Table B shows these minimums for the most common motor types.

D-4 Insufficient wrap on the small sheave can require excessive belt tension to prevent slippage. This condition may require redesign, either using more belts, increasing the center distance or using a backside idler with longer belts. This is again a matter for Browning Application Engineering.

Troubleshooting Design Problems

Table B. Application of V-Belt Sheave Dimensions to General-Purpose Motors

Frame No.	Integral-Horsepower Motors - Polyphase Induction				V-Belt Sheave (Inches)	
	Horsepower at Synchronous Speed, Rpm				Conventional A, B, C, D, & E Minimum Pitch Diameter, Inches	Narrow 3V, 5V & 8V Minimum Outside Diameter, Inches
	3600	1800	1200	900		
143T	1 1/2	1	3/4	1/2	2.2	2.2
145T	2-3	1 1/2-2	1	3/4	2.4	2.4
182T	3	3	1 1/2	1	2.4	2.4
182T	5	-	-	-	2.6	2.4
184T	-	-	2	1 1/2	2.4	2.4
184T	5	-	-	-	2.6	2.4
184T	7 1/2	5	-	-	3.0	3.0
213T	7 1/2-10	7 1/2	3	2	3.0	3.0
215T	10	-	5	3	3.0	3.0
215T	15	10	-	-	3.8	3.8
254T	15	-	7 1/2	5	3.8	3.8
254T	20	15	-	-	4.4	4.4
256T	20-25	-	10	7 1/2	4.4	4.4
256T	-	20	-	-	4.6	4.4
284T	-	-	15	10	4.6	4.4
284T	-	25	-	-	5.0	4.4
286T	-	30	20	15	5.4	5.2
324T	-	40	25	-20	6.0	6.0
326T	-	50	30	25	6.8	6.8
364T	-	-	40	30	6.8	6.8
364T	-	60	-	-	7.4	7.4
365T	-	-	50	40	8.2	8.2
365T	-	75	-	-	9.0	8.6
404T	-	-	60	-	9.0	8.0
404T	-	-	-	50	9.0	8.4
404T	-	100	-	-	10.0	8.6
405T	-	-	75	60	10.0	10.0
405T	-	100	-	-	10.0	8.6
405T	-	125	-	-	11.5	10.5
444T	-	-	100	-	11.0	10.0
444T	-	-	-	75	10.5	9.5
444T	-	125	-	-	11.0	9.5
444T	-	150	-	-	-	10.5
445T	-	-	125	-	12.5	12.0
445T	-	-	-	100	10.5	12.0
445T	-	150	-	-	-	10.5
445T	-	200	-	-	-	13.2

*NEMA Standard, MG1-14.42

Troubleshooting Design Problems

D-5 Backside idlers can create problems because they cause V-belts to bend opposite to the way they were designed. Care must be taken to see that a backside idler is large enough in diameter to reduce harmful stresses, which often cause cracks on the underside of the belt. Table A (under **D-3**) also shows these minimum recommended diameters.

Design and Installation Suggestions

Browning® Gripbelt® "V" Drives are primarily intended for the transmission of power with relatively high speed driving units. Their acceptance by industry covers a broad field of applications including installations on a wide variety of different types of equipment, including speed increasing drives, V-flat drives, quarter-turn drives, multiple shaft drives and conveyors. Many such applications are regularly being designed and installed using stock parts.

Regardless of whether drives consist of stock or special items there are certain primary conditions to consider with respect to the design of satisfactory drives. Those most commonly encountered are:

1. Drives should always be installed with provision for center distance adjustment. This is essential, because an adjustment is necessary after the belt has set and seated properly in the groove of the sheave. If centers must be fixed, idlers should be used.
2. If possible, centers should not exceed 3 times the sum of the sheave diameters nor be less than the diameter of the large sheave.
3. If possible, the arc of contact of the belt on the smaller sheave should not be less than 120°.
4. Belt speeds with cast iron sheaves cannot exceed 6500 feet per minute. Another type of drive is usually more desirable for speeds under 1000 feet per minute.
5. Special or dynamic balance may need consideration for belts speeds exceeding 5000 feet per minute.
6. Full consideration and allowance for overload capacity in drives increases belt life and improves operation. Study the Overload Service Factors in this section carefully.
7. Severe temperature can have a major effect on belt life. There should be a full and free circulation of air around the drive. All drives operating in explosive atmospheres should be well grounded and use static conducting belts.

Watch these points particularly when installing drives:

Design and Installation Suggestions

1. Be sure that shafts are parallel and sheaves are in proper alignment. Check after eight hours of operation.
2. Do not drive sheaves on or off shafts. Be sure shaft and keyway are smooth and that bore and key are of correct size. Remove burrs by dressing lightly with finishing file. Wipe shaft, key and bore clean with oil. Tighten screws carefully. Recheck and re-tighten after eight hours of operation.
3. Belts should never be forced over sheaves. More belts are broken from this cause than from actual failure in service. See Table No. 1 and 1A on page 38 and 39.
4. In mounting belts, be sure that the slack in each and every belt is on the same side of the drive. This should be the slack side of the drive.
5. Belt tension should be reasonable. When in operation the tight side of belts should be in a straight line from sheave to sheave and with a slight bow on the slack side. Check belt tension after eight hours of operation. All drives should be inspected periodically to be sure belts are under proper tension and not slipping.

For more detailed tensioning instructions and an inexpensive tension checker, see page 54.

6. Do not install new sets of belts in drives where the sheaves have worn grooves. Such sheaves should be replaced with new sheaves to insure a proper fit of the belts in the grooves, thus eliminating possibility of premature belt failure.
7. Keep belts clean. Do not use belt dressing.
8. When making replacement of belts on a drive, be sure to replace the entire set with a new set of matched belts. Failure to do this will probably result in premature breakage of new (and probably shorter) belts mixed with old ones.
9. Keep extra belts stored in a cool, dark, dry place.

Caution – Install guards according to local and national codes.

Design and Installation Suggestions
**Minimum Center Distance Allowance
for Belt Installation and Take-Up**
Table No. 1

Belt No.	Allowance for Installation				Allowance for Initial Tensioning and Subsequent Take-Up
	A	B	C	D	All Sections
26 - 35	0.8	1.0	–	–	1.0
38 - 55	0.8	1.0	1.5	–	1.5
60 - 85	0.8	1.3	1.5	–	2.0
90 - 112	1	1.3	1.5	–	2.5
120 - 144	1	1.3	1.5	2.0	3.0
158 - 180	–	1.3	2.0	2.0	3.5
195 - 210	–	1.5	2.0	2.0	4.0
240	–	1.5	2.0	2.5	4.5
220 - 300	–	1.5	2.0	2.5	5.0
330 - 390	–	–	2.0	2.5	6.0
420 and over	–	–	2.3	3.0	1½% of Belt Length

Design and Installation Suggestions
**Minimum Center Distance Allowance
for Belt Installation and Take-Up**
Table No. 1A

Belt No.	Allowance for Installation			Allowance for Initial Tensioning and Subsequent Take-Up
	3V	5V	8V	All Sections
250 - 475	.5	–	–	1.0
500 - 710	.8	1.0	–	1.2
750 - 1060	.8	1.0	1.5	1.5
1120 - 1250	.8	1.0	1.5	1.8
1320 - 1700	.8	1.0	1.5	2.2
1800 - 2000	–	1.0	1.8	2.5
2120 - 2240	–	1.2	1.8	2.8
2360	–	1.2	1.8	3.0
2500 - 2650	–	1.2	1.8	3.2
2800 - 3000	–	1.2	1.8	3.5
3150	–	1.2	1.8	4.0
3350 - 3550	–	1.5	2.0	4.0
3750	–	–	2.0	4.5
4000 - 5000	–	–	2.0	5.5
5600	–	–	2.0	6.0

Gripbelt® Drive Engineering Data

Basic Drive Selection Procedure

Selections are based on horsepower ratings for single belt and are not corrected for arc of contact, belt length or ratio. Selections based on a 1.0 service factor. Drive calculations based on motor or smaller sheave operating at 1750 RPM.

Application characteristics: Low horsepower

- For single groove low horsepower application (under 3 HP)
- Ideal for fan applications

FHP (Fractional Horsepower) V-belts

Belt Type 3L	Pitch Dia.	1.25*	1.5	1.75	2.0	2.5	3.0	3.5	4.0	4.5	5.0	-	-
	HP Rating	0.09	0.15	0.23	0.29	0.43	0.55	0.61	0.67	0.73	0.78	-	-
Belt Type 4L	Pitch Dia.	1.25*	1.5*	2.0*	2.5	3.0	3.5	4.0	4.5	5.0	5.5	6.0	-
	HP Rating	0.09	0.14	0.29	0.60	0.88	1.17	1.37	1.49	1.61	1.70	1.78	-
Belt Type 5L	Pitch Dia.	2.2*	2.5*	3.0*	3.4	3.9	4.4	4.9	5.4	5.9	6.4	6.9	7.4
	HP Rating	0.36	0.45	0.71	1.07	1.52	1.95	2.26	2.39	2.50	2.59	2.68	2.71

* Below RMA minimum recommended pitch diameter.

Note: For speeds not shown on this page, use tables on pages 108-109. Drives must be corrected for loss in arc of contact.

Gripbelt® Drive Engineering Data

Basic Drive Selection Procedure

Selections are based on horsepower ratings for single belt and are not corrected for arc of contact, belt length or ratio. Selections based on a 1.0 service factor. Drive calculations based on motor or smaller sheave operating at 1750 RPM.

Application characteristics: **Medium horsepower**

- For industrial applications requiring single or multiple V-belt drives
- Transmits more horsepower and has longer life expectancy than FHP V-belts
- Suited for "clutching" applications.

A, B and C Type V-Belts

Belt Type A	Pitch Dia.	2.00*	2.20*	2.60*	3.00	3.40	3.70	4.00	4.40	4.70	5.00	5.40	5.70	6.00	6.40	7.00	8.00	
	HP Rating	0.90	1.17	1.69	2.23	2.95	3.40	4.00	4.69	5.20	5.96	6.35	6.83	7.30	7.91	8.81	10.22	
Belt Type B	Pitch Dia.	3.00	3.30*	3.80*	4.20*	4.60*	5.00*	5.40	5.80	6.20	6.60	7.00	7.40	8.00	8.60	9.00	9.40	
	HP Rating	1.58	2.47	3.34	4.19	5.10	6.16	7.21	8.22	9.22	10.19	11.13	12.06	13.39	14.66	15.48	16.27	
Belt Type C	Pitch Dia.	5.60	7.00*	7.40*	7.80*	8.20*	8.60*	9.00	9.40	9.80	10.20	11.00	12.00	14.00	-	-	-	-
	HP Rating	6.94	12.09	13.62	15.11	16.56	17.96	19.32	20.62	21.88	23.09	25.35	27.86	31.76	-	-	-	-

* Below RMA minimum recommended pitch diameter.

Note: For speeds not shown on this page, use tables on pages 108-109. Drives must be corrected for loss in arc of contact.

Gripbelt® Drive Engineering Data

4 Basic Drive Selection Procedure

Selections are based on horsepower ratings for single belt and are not corrected for arc of contact, belt length or ratio. Selections based on a 1.0 service factor. Drive calculations based on motor or smaller sheave operating at 1750 RPM.

Application characteristics: **Medium/High horsepower**

- For industrial applications requiring single or multiple V-belt drives
- Raw edge, cogged
- Transmits more horsepower than comparable A, B, and C belts
- Raw edge design provides more aggressive gripping with less belt slippage
- Cogged construction allows belt flex easier around drive sheave and run cooler than non-cogged belts
- Not for use on (clutching) applications because of aggressive grip

AX, BX and CX Type V-Belts

Belt Type AX	Pitch Dia.	2.00*	2.20	2.60	3.00	3.40	3.70	4.00	4.70	5.00	5.40	5.70	6.00	6.40	7.00	8.00	-
	HP Rating	1.24	1.58	2.25	2.90	3.53	3.99	4.46	5.67	6.18	6.84	7.34	7.82	8.45	9.39	10.88	
Belt Type BX	Pitch Dia.	3.00*	3.40*	3.80	4.20	4.60	5.00	5.40	5.80	6.20	6.60	7.00	7.40	8.00	8.60	9.00	9.40
	HP Rating	3.72	4.62	5.50	6.36	7.19	8.08	9.19	10.27	11.34	12.39	13.41	14.42	15.89	17.32	18.23	19.13
Belt Type CX	Pitch Dia.	5.60*	7.00	7.40	7.80	8.20	8.60	9.00	9.40	9.80	10.20	11.00	12.00	14.00	-	-	-
	HP Rating	14.10	18.35	19.49	20.60	21.66	23.14	24.61	26.05	27.44	28.79	31.37	34.32	39.31	-	-	-

* Below RMA minimum recommended pitch diameter.

Note: For speeds not shown on this page, use tables on pages 108-109. Drives must be corrected for loss in arc of contact.

Gripbelt® Drive Engineering Data

Basic Drive Selection Procedure

Selections are based on horsepower ratings for single belt and are not corrected for arc of contact, belt length or ratio. Selections based on a 1.0 service factor. Drive calculations based on motor or smaller sheave operating at 1750 RPM.

Application characteristics: **High horsepower**

- For industrial applications requiring single or multiple V-belt drives
- Transmits substantially more horsepower than A, AX, B, BX, C and CX, which allows for more compact drive systems (smaller sheave O.D. and/or fewer grooves)
- Raw edge, cogged

3VX and 5VX Type V-Belts

Belt Type	Pitch Dia.		2.15	2.30	2.45	2.60	2.95	3.10	3.30	3.60	4.45	4.70	4.95	5.25	5.95	6.85	7.95	10.55
	HP Rating																	
3VX	1.37		1.63	1.89	2.15	2.75	3.01	3.34	3.85	5.25	5.65	6.05	6.53	7.63	9.01	10.64	14.22	
Belt Type	Pitch Dia.		4.30	4.55	4.80	5.10	5.40	5.70	5.90	6.20	6.50	6.70	7.00	7.40	7.90	8.40	9.10	10.50
	HP Rating																	
5VX	8.23		9.40	10.55	11.93	13.30	14.66	15.56	16.89	18.22	19.10	20.41	22.13	24.26	26.35	29.23	30.84	

* Below RMA minimum recommended pitch diameter.

Note: For speeds not shown on this page, use tables on pages 108-109. Drives must be corrected for loss in arc of contact.

Gripbelt[®] Drive Engineering Data**Overload Service Factors**

Load and operating characteristics of both the driving and driven units must be considered thoroughly in the selection of Browning Gripbelt Drives. It is essential that all drives be designed for maximum load conditions to be encountered.

Most drives will at some time be overloaded, perhaps only momentarily. It is good practice to have predetermined drive capacity to handle this overload. This predetermined drive capacity helps protect against breakdowns due to premature belt failure. The use of an extra belt will pay for itself many times over by increasing the life of all the belts more than the proportionate cost of the extra belt.

For good design and satisfactory drive life all drives must be selected with careful consideration to two fundamental conditions:

1. The motor must have greater capacity than the driven unit.
2. The drive must have greater capacity than the motor.

A careful consideration of Overload Service Factors for various types of driven units, drivers, type of starting, frequency of maintenance and other drive conditions is extremely important for satisfactory performance and life.

The following tables on page 45 are suggested Overload Service Factors for various typical driven units.

▲ CAUTION

ⓘ Drives requiring high Overload Service Factors, such as crushing machinery, certain reciprocating compressors, etc. subjected to heavy shock load without suitable fly wheels, may need heavy duty web type sheaves rather than standard arm type. For any such application, consult Application Engineering.

Gripbelt® Drive Engineering Data

Suggested Overload Service Factors for Typical Applications

TYPES OF DRIVEN MACHINES	DRIVING UNITS 1		
	AC Motors; Normal Torque, SquirrelCage, Synchronous and Split Phase. DC Motors; Shunt Wound. Multiple Cylinder Internal Combustion Engines.		
	Intermittent (3-5 Hours Daily or Seasonal)	Normal (8-10 Hours Daily)	Continuous (16-24 Hours Daily)
Blowers and Exhausters Pumps and Compressors Fans up to 10 HP	1.0	1.1	1.2
Fans Over 10 HP Positive Displacement Rotary Pumps	1.1	1.2	1.3
Positive Displacement Blowers	1.2	1.3	1.4
TYPES OF DRIVEN MACHINES	DRIVING UNITS 2		
	AC Motors; High Torque, High Slip, Repulsion-Induction, Single Phase, Series Wound and Slip Ring. DC Motors; Series Wound and Compound Wound. Single Cylinder Internal Combustion Engines. Line Shafts. Clutches.		
	Intermittent (3-5 Hours Daily or Seasonal)	Normal (8-10 Hours Daily)	Continuous (16-24 Hours Daily)
Blowers and Exhausters Pumps and Compressors Fans up to 10 HP	1.1	1.2	1.3
Fans Over 10 HP Positive Displacement Rotary Pumps	1.2	1.3	1.4
Positive Displacement Blowers	1.4	1.5	1.6

● A minimum Service Factor of 2.0 is suggested for equipment subject to chocking.

Service factor should be increased by 0.2 on drive units with a increaser drive speed of 2200 RPM or lower when using a 1750 RPM motor. This is a speed-up ratio of 1.25 or less. For speed increaser drives or speed-up drives greater than 2200 RPM, the recommendation is to use a 2.0 service factor.

Gripbelt® Drive Engineering Data**Datum System**

In December, 1987, RMA/MPTA adopted Standard IP20-1988. This standard supersedes IP20-1977 and affected the A, B, C, and D belts and sheaves. Those products in this catalog are in accordance with IP20-1988 which incorporates the Datum Diameter System.

The Datum System specifies the Datum Diameter as the effective diameter for determining the pitch length of the belt for center distance calculation. In this catalog, Datum Diameter (D.D.) is now listed for the A, B, C, and D sheaves and is equal to the old Pitch Diameter (P.D.) shown in previous catalogs.

Belt Velocity

Belt velocity is not needed for calculation of drives, as the horsepower ratings shown are based on the R.P.M. of the sheave. If belt velocity is desired for any reason, use the formula:

Belt Velocity in Feet per Minute (FPM) =

D.D. or P.D. of Sheave × .2618 × Speed of Sheave (RPM)

Cast Iron Sheaves must not be used beyond 6500 FPM belt speed. Since the majority of stock sheaves are made of cast iron, we list no ratings above 6500 FPM.

Some types of belts lose ratings before they reach 6500 FPM and other types continue to increase beyond 6500 FPM. The Basic Rating Tables and the Drive Selection Tables reflect these variations.

Special Balance

Functionally, speeds up to 6500 FPM are acceptable; however, on applications where vibration requirements are critical, special balancing (usually dynamic) for speeds above 5000 FPM may be considered. Factors to be considered for special balance requirements are: rigidity of drive mounting, whether noise created by a level of vibration would be prohibitive, etc. Many drives are in service running at speeds up to 6500 FPM without special balancing.

Gripbelt® Drive Engineering Data
Center Distance and Belt Length**Interpolation**

For every inch of belt length difference there is approximately 1/2 inch center distance change. All belt numbers reflect a relation if it is pitch length, outside length or inside length. An A26 belt is 2" longer than an A24 belt; a B105 belt is 15" longer than a B90 belt; a 3V335 belt is 8.5" longer than a 3V250 belt, etc.

Interpolation example:

If an A128 belt gives 50.0" C.D. and an A96 gives 34.0 C.D. , then an A112 belt gives 42.0 C.D.

If a 5V1200 belt gives 83.1" C.D. and a 5V1600 gives 63.1 C.D., then a 5V1800 belt gives 73.1 C.D.

Center distance and belt lengths determined by interpolation are usually close enough as all drives should provide for take-up as indicated on pages 38 and 39. If closer calculation is necessary for any reason use the following formula:

$$L = 2C + 1.57 (D + d) + \frac{(D - d)^2}{4C}$$

where:

- L = Pitch Length of Belt
- C = Center Distance
- D = Datum or Pitch Diameter of Large Sheave
- d = Datum or Pitch Diameter of Small Sheave

Gripbelt[®] Drive Engineering Data

Driven Speed Variations

All V-Belt Drives will vary slightly from the speeds shown in the Drive Selection Tables. These variations are due to different motor speeds depending on load, changing frequencies (on A.C. Motors) or voltage (on D.C. Motors), varying tensions and resulting slip, and allowable manufacturing tolerances in belts and sheaves. Also, actual sheave pitch diameters and actual belt pitch lines have been changed slightly over the years by all manufactures but catalog data has not been changed to reflect this.

In the few instances where very close speed tolerances are required, contact Application Engineering for assistance or use the Browning Edge Selection Program.

Speed-Up, Quarter-Turn, and V-Flat Drives

These drives occur infrequently and should be referred to Browning for special design considerations.

Gripbelt® Drive Engineering Data

Belt Section Selection Chart

Table No. 1

HP	Belt Section			
1/2	A	AX		
3/4	A	AX		
1	A	AX		
1 1/2	A	AX		
2	A	AX		
3	AX	A	BX	
5	BX	AX	B	A
7 1/2	BX	B	5VX	3VX
10	5VX, BX	B	3VX	AX
15	5VX, BX	B	3VX	AX
20	5VX	BX	B	3VX
25	5VX	BX	B	3VX
30	5VX	BX	B	3VX
40	5VX, 5V	BX	B	
50	5VX, 5V	BX	B	CX
60	5VX, 5V	BX	B	CX
75	5VX, 5V	CX	BX	C
100	5VX, 5V	CX	C	
125	5VX, 5V	CX	C	
150	5VX, 5V	CX	C	
200	5VX, 5V	CX		
250	5VX, 5V	CX		

The best drive will usually be found by using Belt Section from the first column. If, for any reason, such as sheave shortage, this drive is not suitable, go to the next column.

"AX" drives are found in the "A" Drive Selection Tables; "BX" in the "B" Tables, etc.

Gripbelt® Drive Engineering Data

Correction Factor for Belt Length

Longer belts have greater horsepower ratings because of less frequent flexure around sheaves.

Multiply H. P. ratings by appropriate factor from table below to get the final corrected horsepower.

Table No. 1

Nominal Length	A	B	C	Nominal Length	A	B	C	D	E
26	.81	—	—	90	1.06	1.00	.91	—	—
31	.84	—	—	93	—	1.01	—	—	—
32	.85	—	—	96	1.08	1.02	.92	—	—
33	.86	—	—	97	—	1.02	—	—	—
34	.86	—	—	99	—	1.02	—	—	—
35	.87	.81	—	100	—	1.03	—	—	—
36	.87	—	—	103	—	1.03	—	—	—
37	.88	—	—	105	1.10	1.04	.94	—	—
38	.88	.83	—	108	—	1.04	—	—	—
42	.90	.85	—	109	—	—	.94	—	—
43	.90	—	—	110	1.11	—	—	—	—
46	.92	.87	—	112	1.11	1.05	.95	—	—
48	.93	.88	—	115	—	—	.96	—	—
50	—	.89	—	116	—	1.06	—	—	—
51	.94	.89	.80	120	1.13	1.07	.97	.86	—
52	—	.89	—	124	—	1.07	—	.87	—
53	.95	.90	—	128	1.14	1.08	.98	—	—
54	.95	.90	—	133	—	1.08	—	—	—
55	.96	.90	—	136	1.15	1.09	.99	—	—
56	.96	.90	—	144	1.16	1.11	1.00	.90	.88
58	.97	.91	—	150	—	1.12	1.01	—	—
59	—	.91	—	158	1.17	1.13	1.02	.92	—
60	.98	.92	.82	162	—	1.13	1.03	.92	—
61	—	.92	—	173	1.18	1.15	1.04	.93	—
62	.99	.93	—	180	1.19	1.16	1.05	.94	.91
63	—	.93	—	195	—	1.18	1.07	.96	.92
64	.99	.93	—	210	—	1.19	1.08	.96	.94
65	—	.94	—	225	—	1.20	1.09	.98	.95
66	1.00	.94	—	240	—	1.22	1.11	1.00	.96
67	—	.94	—	255	—	1.23	1.12	1.01	—
68	1.00	.95	.85	270	—	1.25	1.14	1.03	.99
70	1.01	.95	—	285	—	1.26	1.15	1.04	—
71	1.01	.95	—	300	—	1.27	1.16	1.05	1.01
75	1.02	.97	.87	315	—	1.28	1.17	1.06	—
77	—	.98	—	330	—	—	1.19	1.07	1.03
78	1.03	.98	—	345	—	—	1.20	1.08	—
79	—	.98	—	360	—	1.31	1.21	1.09	1.05
80	1.04	.98	—	390	—	—	1.23	1.11	1.07
81	—	.98	.89	420	—	—	1.24	1.12	1.09
82	—	.99	—	480	—	—	—	1.16	1.12
83	—	.99	—	540	—	—	—	1.18	1.14
85	1.05	.99	.90	600	—	—	—	1.20	1.17
88	—	1.00	—						

Gripbelt® Drive Engineering Data

Multiply H. P. ratings by appropriate factor from table below to get the final corrected horsepower.

Table No. 2

Belt Length	Cross Section			Belt Length	Cross Section		
	3V	5V	8V		3V	5V	8V
25.0	.83	—	—	112.0	1.11	.98	.88
26.5	.84	—	—	118.0	1.12	.99	.89
28.0	.85	—	—	125.0	1.13	1.00	.90
30.0	.86	—	—	132.0	1.14	1.01	.91
31.5	.87	—	—	140.0	1.15	1.02	.92
33.5	.88	—	—	150.0	—	1.03	.93
35.5	.89	—	—	160.0	—	1.04	.94
37.5	.91	—	—	170.0	—	1.05	.95
40.0	.92	—	—	180.0	—	1.06	.95
42.5	.93	—	—	190.0	—	1.07	.96
45.0	.94	—	—	200.0	—	1.08	.97
47.5	.95	—	—	212.0	—	1.09	.98
50.0	.96	.85	—	224.0	—	1.09	.98
53.0	.97	.86	—	236.0	—	1.10	.99
5.0	.98	.87	—	250.0	—	1.11	1.00
60.0	.99	.88	—	265.0	—	1.12	1.01
63.0	1.00	.89	—	280.0	—	1.13	1.02
67.0	1.01	.90	—	300.0	—	1.14	1.03
71.0	1.02	.91	—	315.0	—	1.15	1.03
75.0	1.03	.92	—	335.0	—	1.16	1.04
80.0	1.04	.93	—	355.0	—	1.17	1.05
85.0	1.06	.94	—	375.0	—	—	1.06
90.0	1.07	.95	—	400.0	—	—	1.07
95.0	1.08	.96	—	425.0	—	—	1.08
100.0	1.09	.96	.87	450.0	—	—	1.09
106.0	1.10	.97	.88				

Correction Factor for Loss in Arc of Contact

The loss of arc of contact from 180° for different drives can be determined in the following manner:

$$\text{Loss in Arc of Contact (in degrees)} = \frac{(D - d) 57}{C}$$

The Correction Factors for loss in arc of contact in degrees are;

Table No. 3

Loss in Arc of Contact	Correction Factor	Loss in Arc of Contact	Correction Factor
0°	1.00	50°	.86
5°	.99	55°	.84
10°	.98	60°	.83
15°	.96	65°	.81
20°	.95	70°	.79
25°	.93	75°	.76
30°	.92	80°	.74
35°	.90	85°	.71
40°	.89	90°	.69
45°	.87		

Gripbelt® Drive Engineering Data

Table No. 4

Belt Selection	Nominal Belt Size	Add to P.D. to get O.D.	Minimum Recommended Pitch Diameter*	C	D
A	1/2" x 5/16"	.25"	3.00"	3/8"	5/8"
B	21/32 x 13/32	.35	5.40	1/2	3/4
C	7/8 x 17/32	.40	9.00	11/16	1
D	1 1/4 x 3/4	.64	13.00	7/8	1 7/16
E	1 1/2 x 29/32	.82	21.00	1 1/8	1 3/4
3V	3/8 x 5/16	.05	2.60	11/32	13/32
5V	5/8 x 7/16	.10	7.00	1/2	11/16
8V	1 x 7/8	.20	12.50	3/4	1 1/8

* The minimum recommended pitch diameters listed above are RMA and MPTA Standards recommendations. Many sheaves with diameters smaller than these recommendations are made and used. If a rating for a "sub-minimum diameter" sheave is published in the selection tables and the drive is properly installed, it should give the same theoretical life as a drive using sheave diameters equal to or greater than the minimums shown above.

Gripbelt® Drive Engineering Data

$$1 \text{ HP} = 54" \text{ lbs. @ 1160 RPM}$$

$$1 \text{ HP} = 36" \text{ lbs. @ 1750 RPM}$$

$$\text{HP} = \frac{\text{FORCE} \times \text{FPM}}{33,000}$$

$$\text{HP} = \frac{\text{T " lbs.} \times \text{RPM}}{63,025}$$

$$\text{HP} = \frac{\text{T ' lbs.} \times \text{RPM}}{5,252}$$

$$\text{T " lbs.} = \frac{63,025 \times \text{HP}}{\text{RPM}}$$

$$\text{T ' lbs.} = \frac{5,252 \times \text{HP}}{\text{RPM}}$$

$$\text{FPM} = .2618 \times \text{DIA.} \times \text{RPM}$$

$$\text{RPM} = \frac{63,025 \times \text{HP}}{\text{TORQUE}}$$

$$\text{T} = \text{FORCE} \times \text{LEVER ARM}$$

$$\text{F} = \frac{\text{TORQUE}}{\text{RADIUS}}$$

$$\text{RPM} = \frac{\text{FPM}}{.2618 \times \text{DIA.}}$$

$$\text{OL} = \frac{2\text{TK}}{\text{D}}$$

$$\text{K} = 1.0 \text{ for Chain Drives}$$

$$1.25 \text{ for Gear Drives}$$

$$1.25 \text{ for Gearbelt Drives}$$

$$1.50 \text{ for V-Belt Drives}$$

$$2.50 \text{ for Flat Belt Drives}$$

$$\text{LINEAL SHAFT EXPANSION}$$

$$= .0000063 \times \text{length}$$

in inches

$$\times \text{temperature inc.}$$

in degrees F

$$\text{KW} = \text{HP} \times .7457$$

$$\text{IN.} = \text{MM}/25.4$$

$$\text{TEMP } ^\circ\text{C} = (^\circ\text{F}-32) .556$$

$$\text{Kg} = \text{LBS} \times 2.205$$

Gripbelt® Drive Engineering Data

Tensioning B-Belt Drives

General rules of tensioning.

1. Ideal tension is the lowest tension at which the belt will not slip under peak load conditions.
2. Check tension frequently during the first 24 - 48 hours of operation.
3. Over tensioning shortens belt and bearing life.
4. Keep belts free from foreign material which may cause slip.
5. Make V-drive inspection on a periodic basis. Tension when slipping. Never apply belt dressing as this will damage the belt and cause early failure.

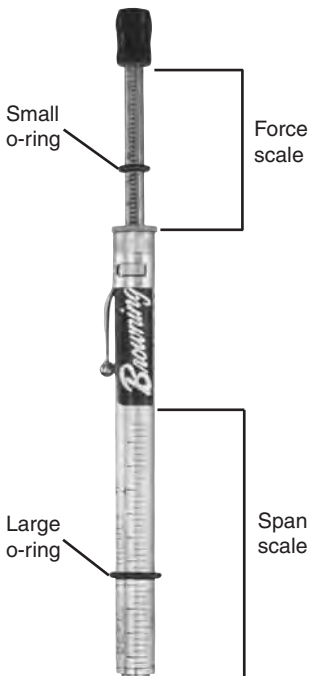

Table No. 1
FHP Belts
Deflection Force

Cross Section	Small P.D. Range	Lbs	
		Min.	Max.
3L	1.25 - 1.75	1/2	5/8
	2.00 - 2.25	5/8	7/8
	2.50 - 3.00	3/4	1 1/8
4L	2.10 - 2.80	1/8	1 5/8
	3.00 - 3.50	1/2	2 1/8
	3.70 - 5.00	1 7/8	2 5/8
5L	3.00 - 4.20	2	2 7/8
	4.50 - 5.20	2 3/8	3 3/8

Part Number "Belt Tension Checker"

Gripbelt® Drive Engineering Data

Tension Measurement Procedure

1. Measure the belt span (see illustration below).
2. Position bottom of the large o-ring on the span scale at the measured belt span.
3. Set the small o-ring on the deflection force scale to zero.
4. Place the tension checker squarely on one belt at the center of the belt span. Apply a force on the plunger and perpendicular to the belt span until the bottom of the large o-ring is even with the top of the next belt or with the bottom of a straight edge laid across the sheaves.
5. Remove the tension checker and read the force applied from the bottom of the small o-ring on the deflection force scale.
6. Compare the force you have applied with the values given in Table No. 2 on page 56. The force should be between the minimum and maximum shown. The maximum value is shown for "New Belt" and new belts should be tensioned at this value to allow for expected tension loss. Used belts should be maintained at the minimum value as indicated in Table No.2 on page 56.

Note: The ratio of deflection to belt span is 1:64.

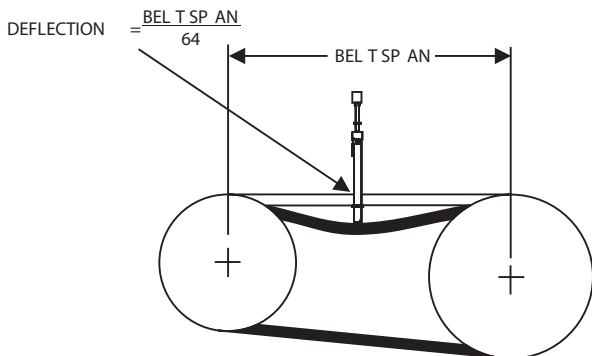

The above method of tensioning belt drives is to be used when a drive has been selected in accordance with the suggestions listed in the drive selection tables of the HVAC catalog. For drives with service factor greater than 1.5, consult Application Engineering. For exact tension calculations use the Emerson Power Transmission Edge Selection Program.

Gripbelt® Drive Engineering Data
Table No. 2 Sheave Diameter - Inches

Cross Section	Smallest Sheave Diameter Range	RPM Range
A, AX	3.0 - 3.6	1000-2500
		2501-4000
	3.8 - 4.8	1000-2500
		2501-4000
	5.0 - 7.0	1000-2500
		2501-4000
B, BX	3.4 - 4.2	860-2500
		2501-4000
	4.4 - 5.6	860-2500
		2501-4000
	5.8 - 8.6	860-2500
		2501-4000
C, CX	7.0 - 9.0	500-1740
		1741-3000
	9.5 - 16.0	500-1740
		1741-3000
D	12.0 - 16.0	200-850
		851-1500
	18.0 - 20.0	200-850
		851-1500
3V, 3VX	2.2 - 2.4	1000-2500
		2501-4000
	2.65 - 3.65	1000-2500
		2501-4000
	4.12 - 6.90	1000-2500
		2501-4000
5V, 5VX	4.4 - 6.7	500-1749
		1750-3000
		3001-4000
	7.1 - 10.9	500-1740
		1741-3000
	11.8 - 16.0	500-1740
1741-3000		
8V	12.5 - 17.0	200-850
		851-1500
	18.0 - 22.4	200-850
		851 - 1500

Gripbelt® Drive Engineering Data

Deflection Force - Lbs.

Belt Deflection Force			
Super Gripbelts and Unnotched Gripbands		Gripnotch™ Belts and Notched Gripbands	
Used Belt	New Belt	Used Belt	New Belt
3.7	5.5	4.1	6.1
2.8	4.2	3.4	5.0
4.5	6.8	5.0	7.4
3.8	5.7	4.3	6.4
5.4	8.0	5.7	9.4
4.7	7.0	5.1	7.6
-	-	4.9	7.2
-	-	4.2	6.2
5.3	7.9	7.1	10.5
4.5	6.7	7.1	9.1
6.3	9.4	8.5	12.6
6.0	8.9	7.3	10.9
11.5	17.0	14.7	21.8
9.4	13.8	11.9	17.5
14.1	21.0	15.9	23.5
12.5	18.5	14.6	21.6
24.9	37.0	-	-
21.2	31.3	-	-
30.4	45.2	-	-
25.6	38.0	-	-
-	-	3.3	4.9
-	-	2.9	4.3
3.6	5.1	4.2	6.2
3.0	4.4	3.8	5.6
4.9	7.3	5.3	7.9
4.4	6.6	4.9	7.3
-	-	10.2	15.2
-	-	8.8	13.2
-	-	5.6	8.5
12.7	18.9	14.8	22.1
11.2	16.7	13.7	20.1
15.5	23.4	17.1	25.5
14.6	21.8	16.8	25.0
33.0	49.3	-	-
26.8	39.9	-	-
39.6	59.2	-	-
35.3	52.7	-	-



V-Belt Drive Advantages

V-belt drives provide many maintenance advantages that help in your daily struggle to reduce equipment repairs and to hold forced downtime to the lowest possible level.

1. They are rugged—they will give years of trouble-free performance when given just reasonable attention... even under adverse conditions.
2. They are clean—require no lubrication.
3. They are efficient—performing with an average of 94-98% efficiency.
4. They are smooth starting and running.
5. They cover extremely wide horsepower ranges.
6. They permit a wide range of driven speeds, using standard electric motors.
7. They dampen vibration between driving and driven machines.
8. They are quiet.
9. They act as a “safety fuse” in the power drive because they refuse to transmit a severe overload of power, except for a very brief time.
10. V-belts and sheaves **wear gradually**—making preventive corrective maintenance simple and easy.



“358” Gripbelt®

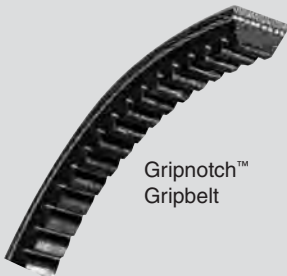

Gripnotch™
Gripbelt

Offers the largest selection of V-Belts in the universe!

Browning is universally known for V-belt drives. In fact, nowhere else can you find such a complete range of V-belting — and the sheaves to run them — all in stock. Choose the type that's best for your application — Classical, "358" and FHP.

- Matched Belts -

And there's no problem with matched belt sizes either. Browning offers the "**CODE 1**" **one-match** belt system on all classical and "358" belts, allowing easy selection with just one match number for each belt size. The **CODE 1** symbol on any Browning belt provides matching tolerances tighter than ANSI (American National Standards Inc.). Machine matching of belts is also available for precision match requirements.

Wherever you are in the universe — make Browning your first choice in V-belts.

Note: Belt matching is available upon request. The product will ship from our National Distribution Center.



V-S Variable
Speed Gripbelt®



Super
Gripbelt



Super Gripbelt®

Table No. 1 Super Gripbelt belts are static conducting.

Belt No.	Length		Wt. Lbs.	Belt No.	Length		Wt. Lbs.
	Outside	Pitch			Outside	Pitch	
A20	22.2"	21.3"	.2	A60	62.2"	61.3"	.4
A21	23.2	22.3	.2	A61	63.2	62.3	.4
A22	24.2	23.3	.2	A62	64.2	63.3	.4
A23	25.2	24.3	.2	A63	65.2	64.3	.4
A24	26.2	25.3	.2	A64	66.2	65.3	.4
A25	27.2	26.3	.2	A65	67.2	66.3	.5
A26	28.2	27.3	.2	A66	68.2	67.3	.5
A27	29.2	28.3	.2	A67	69.2	68.3	.5
A28	30.2	29.3	.2	A68	70.2	69.3	.5
A29	31.2	30.3	.2	A69	71.2	70.3	.5
A30	32.2	31.3	.2	A70	72.2	71.3	.5
A31	33.2	32.3	.2	A71	73.2	72.3	.5
A32	34.2	33.3	.2	A72	74.2	73.3	.5
A33	35.2	34.3	.2	A73	75.2	74.3	.5
A34	36.2	35.3	.2	A74	76.2	75.3	.5
A35	37.2	36.3	.2	A75	77.2	76.3	.5
A36	38.2	37.3	.3	A76	78.2	77.3	.5
A37	39.2	38.3	.3	A77	79.2	78.3	.5
A38	40.2	39.3	.3	A78	80.2	79.3	.5
A39	41.2	40.3	.3	A79	81.2	80.3	.5
A40	42.2	41.3	.3	A80	82.2	81.3	.5
A41	43.2	42.3	.3	A81	83.3	82.3	.5
A42	44.2	43.3	.3	A82	84.2	83.3	.6
A43	45.2	44.3	.3	A83	85.2	84.3	.6
A44	46.2	45.3	.3	A84	86.2	85.3	.6
A45	47.2	46.3	.3	A85	87.2	86.3	.6
A46	48.2	47.3	.3	A86	88.2	87.3	.6
A47	49.2	48.3	.3	A87	89.2	88.3	.6
A48	50.2	49.3	.3	A88	90.2	89.3	.6
A49	51.2	50.3	.4	A89	91.2	90.3	.6
A50	52.2	51.3	.4	A90	92.2	91.3	.6
A51	53.2	52.3	.4	A91	93.2	92.3	.6
A52	54.2	53.3	.4	A92	94.2	93.3	.6
A53	55.2	54.3	.4	A93	95.2	94.3	.6
A54	56.2	55.3	.4	A94	96.2	95.3	.6
A55	57.2	56.3	.4	A95	97.2	96.3	.6
A56	58.2	57.3	.4	A96	98.2	97.3	.7
A57	59.2	58.3	.4	A97	99.2	98.3	.7
A58	60.2	59.3	.4	A98	100.2	99.3	.7
A59	61.2	60.3	.4	A100	102.2	101.3	.7



Super Gripbelt®

Table No. 2 Super Gripbelt belts are static conducting.

Belt No.	Length		Wt. Lbs.	Belt No.	Length		Wt. Lbs.
	Outside	Pitch			Outside	Pitch	
A103	105.2"	104.3"	.7	B54	57.0	55.8	.6
A105	107.2	106.3	.7	B55	58.0	56.8	.6
A110	112.2	111.3	.8	B56	59.0	57.8	.6
A112	114.2	113.3	.8	B57	60.0	58.8	.7
A120	122.2	121.3	.8	B58	61.0	59.8	.7
A125	127.2	126.3	.9	B59	62.0	60.8	.7
A128	130.2	129.3	.9	B60	63.0	61.8	.7
A136	138.2	137.3	.9	B61	64.0	62.8	.7
A144	146.2	145.3	1.0	B62	65.0	63.8	.7
A158	160.2	159.3	1.1	B63	66.0	64.8	.7
A173	175.2	174.3	1.2	B64	67.0	65.8	.7
A180	182.2	181.3	1.2	B65	68.0	66.8	.7
B25	28.0	26.8	.3	B66	69.0	67.8	.7
B26	29.0	27.8	.3	B67	70.0	68.8	.7
B28	31.0	29.8	.3	B68	71.0	69.8	.7
B29	32.0	30.8	.3	B69	72.0	70.8	.8
B30	33.0	31.8	.3	B70	73.0	71.8	.8
B31	34.0	32.8	.3	B71	74.0	72.8	.8
B32	35.0	33.8	.3	B72	75.0	73.8	.8
B33	36.0	34.8	.4	B73	76.0	74.8	.8
B34	37.0	35.8	.4	B74	77.0	75.8	.8
B35	38.0	36.8	.4	B75	78.0	76.8	.8
B36	39.0	37.8	.4	B76	79.0	77.8	.8
B37	40.0	38.8	.4	B77	80.0	78.8	.8
B38	41.0	39.8	.4	B78	81.0	79.8	.8
B39	42.0	40.8	.4	B79	82.0	80.8	.8
B40	43.0	41.8	.5	B80	83.0	81.8	.9
B41	44.0	42.8	.5	B81	84.0	82.8	.9
B42	45.0	43.8	.5	B82	85.0	83.8	.9
B43	46.0	44.8	.5	B83	86.0	84.8	.9
B44	47.0	45.8	.5	B84	87.0	85.8	.9
B45	48.0	46.8	.5	B85	88.0	86.8	.9
B46	49.0	47.8	.5	B86	89.0	87.8	1.0
B47	50.0	48.8	.5	B87	90.0	88.8	1.0
B48	51.0	49.8	.5	B88	91.0	89.8	1.0
B49	52.0	50.8	.6	B89	92.0	90.8	1.0
B50	53.0	51.8	.6	B90	93.0	91.8	1.0
B51	54.0"	52.8"	.6				
B52	55.0	53.8	.6				
B53	56.0	54.8	.6				



Super Gripbelt®

Table No. 3 Super Gripbelt belts are static conducting.

Belt No.	Length		Wt. Lbs.	Belt No.	Length		Wt. Lbs.
	Outside	Pitch			Outside	Pitch	
B90	93.0"	91.8"	1.0	B225	226.5"	225.3"	2.5
B91	94.0	92.8	1.0	B240	241.5	240.3	2.6
B92	95.0	93.8	1.0	B255	256.5	255.3	2.8
B93	96.0	94.8	1.0	B270	271.5	270.3	2.9
B94	97.0	95.8	1.0	B285	286.5	285.3	3.1
B95	98.0	96.8	1.0	B300	301.5	300.3	3.2
B96	99.0	97.8	1.1	B315	316.5	315.3	3.4
B97	100.0	98.8	1.1	B360	361.5	360.3	4.0
B98	101.0	99.8	1.1	C51	55.2	53.9	1.0
B99	102.0	100.8	1.1	C55	59.2	57.9	1.1
B100	103.0	101.8	1.1	C60	64.2	62.9	1.2
B101	104.0	102.8	1.1	C68	72.2	70.9	1.3
B103	106.0	104.8	1.1	C72	76.2	74.9	1.4
B105	108.0	106.8	1.1	C75	79.2	77.9	1.4
B106	109.0	107.8	1.1	C78	82.2	80.9	1.5
B108	111.0	109.8	1.2	C81	85.2	83.9	1.6
B111	114.0	112.8	1.2	C85	89.2	87.9	1.6
B112	115.0	113.8	1.2	C90	94.2	92.9	1.7
B116	119.0	117.8	1.3	C96	100.2	98.9	1.8
B120	123.0	121.8	1.3	C97	101.2	99.9	1.8
B123	126.0	124.8	1.3	C99	103.2	101.9	1.9
B124	127.0	125.8	1.3	C100	104.2	102.9	1.9
B126	129.0	127.8	1.3	C101	105.2	103.9	1.9
B128	131.0	129.8	1.4	C105	109.2	107.9	2.0
B133	136.0	134.8	1.4	C108	112.2	110.9	2.0
B136	139.0	137.8	1.5	C109	113.2	111.9	2.0
B140	143.0	141.8	1.5	C111	115.2	113.9	2.1
B144	147.0	145.8	1.6	C112	116.2	114.9	2.1
B148	151.0	149.8	1.6	C115	119.2	117.9	2.1
B150	153.0	151.8	1.6	C120	124.2	122.9	2.3
B154	157.0	155.8	1.6	C124	128.2	126.9	2.4
B158	161.0	159.8	1.7	C128	132.2	130.9	2.4
B162	165.0	163.8	1.7	C136	140.2	138.9	2.6
B173	176.0	174.8	1.7	C144	148.2	146.9	2.8
B180	183.0	181.8	1.9	C148	152.2	150.9	2.8
B190	193.0	191.8	1.9	C150	154.2	152.9	2.9
B191	194.0	192.2	2.0	C158	162.2	160.9	3.0
B195	198.0	196.8	2.0	C162	166.2	164.9	3.1
B205	208.0	206.9	2.0	C173	177.2	175.9	3.3
B210	213.0	211.8	2.2	C180	184.2	182.9	3.4



Super Gripbelt®

Table No. 4 Super Gripbelt belts are static conducting.

Belt No.	Length		Wt. Lbs.
	Outside	Pitch	
C195	199.2"	197.9"	3.7
C210	214.2	212.9	4.0
C225	227.2	225.9	4.3
C240	242.2	240.9	4.6
C255	257.2	255.9	4.9
C270	272.2	270.9	5.2
C285	287.2	285.9	5.4
C300	302.2	300.9	5.7
C315	317.2	315.9	6.0
C330	332.2	330.9	6.3
C345	347.2	345.9	6.6
C360	362.2	360.9	6.9
C390	392.2	390.9	7.5
C420	422.2	420.9	8.0
D120	125.2	123.3	4.0
D128	133.2	131.3	4.4
D144	149.2	147.3	5.0
D158	163.2	161.3	5.3
D162	167.2	165.3	5.5
D173	178.2	176.3	5.8
D180	185.2	183.3	6.0
D195	200.2	198.3	6.3
D210	215.2	213.3	6.8
D225	227.7	225.8	7.1
D240	242.7	240.8	7.7
D255	257.7	255.8	8.1
D270	272.2	270.8	8.9
D285	287.7	285.8	9.8
D300	302.7	300.8	10.5
D315	317.7	315.8	10.8
D330	332.7	330.8	10.6
D345	347.7	345.8	11.7
D460	362.7	360.8	11.5
D390	392.7	390.8	12.4
D420	422.7	420.8	13.4
D450	452.7	450.8	16.3
D480	482.7	480.8	15.8
D540	542.7	540.8	19.9
D600	602.7	600.8	21.6
D660	662.7	660.8	28.8



Gripnotch™ Belts

- Precision molded raw edge construction
- More horsepower in less space
- Notches are molded extra deep
- Oil and heat resistant
- Static conducting

Table No. 1

Belt No.	Length		Wt. Lbs.	Belt No.	Length		Wt. Lbs.
	Outside	Pitch			Outside	Pitch	
AX20	22.2"	21.3"	0.2	AX60	62.2"	61.3"	0.4
AX21	23.2	22.3	0.2	AX61	63.2	62.3	0.4
AX22	24.2	23.3	0.2	AX62	64.2	63.3	0.4
AX23	25.2	24.3	0.2	AX63	65.2	64.3	0.4
AX24	26.2	25.3	0.2	AX64	66.2	65.3	0.4
AX25	27.2	26.3	0.2	AX65	67.2	66.3	0.5
AX26	28.2	27.3	0.2	AX66	68.2	67.3	0.5
AX27	29.2	28.3	0.2	AX67	69.2	68.3	0.5
AX28	30.2	29.3	0.2	AX68	70.2	69.3	0.5
AX29	31.2	30.3	0.2	AX69	71.2	70.3	0.5
AX30	32.2	31.3	0.2	AX70	72.2	71.3	0.5
AX31	33.2	32.3	0.2	AX71	73.2	72.3	0.5
AX32	34.2	33.3	0.2	AX72	74.2	73.3	0.5
AX33	35.2	34.3	0.2	AX73	75.2	74.3	0.5
AX34	36.2	35.3	0.2	AX74	76.2	75.3	0.5
AX35	37.2	36.3	0.2	AX75	77.2	76.3	0.5
AX36	38.2	37.3	0.3	AX76	78.2	77.3	0.5
AX37	39.2	38.3	0.3	AX77	79.2	78.3	0.5
AX38	40.2	39.3	0.3	AX78	80.2	79.3	0.5
AX39	41.2	40.3	0.3	AX79	81.2	80.3	0.5
AX40	42.2	41.3	0.3	AX80	82.2	81.3	0.5
AX41	43.2	42.3	0.3	AX81	83.2	82.3	0.5
AX42	44.2	43.3	0.3	AX82	84.2	83.3	0.5
AX43	45.2	44.3	0.3	AX83	85.2	84.3	0.5
AX44	46.2	45.3	0.3	AX84	86.2	85.3	0.5
AX45	47.2	46.3	0.3	AX85	87.2	86.3	0.6
AX46	48.2	47.3	0.3	AX86	88.2	87.3	0.6
AX47	49.2	48.3	0.3	AX87	89.2	88.3	0.6
AX48	50.2	49.3	0.3	AX88	90.2	89.3	0.6
AX49	51.2	50.3	0.4	AX89	91.2	90.3	0.6
AX50	52.2	51.3	0.4	AX90	92.2	91.3	0.6
AX51	53.2	52.3	0.4	AX91	93.2	92.3	0.6
AX52	54.2	53.3	0.4	AX92	94.2	93.3	0.6
AX53	55.2	54.3	0.4	AX93	95.2	94.3	0.6
AX54	56.2	55.3	0.4	AX94	96.2	95.3	0.6
AX55	57.2	56.3	0.4	AX95	97.2	96.3	0.6
AX56	58.2	57.3	0.4	AX96	98.2	97.3	0.7
AX57	59.2	58.3	0.4	AX97	99.2	98.3	0.7
AX58	60.2	59.3	0.4	AX98	100.2	99.3	0.7
AX59	61.2	60.3	0.4	AX99	101.2	100.3	0.7



Gripnotch™ Belts

- Precision molded raw edge construction
- More horsepower in less space
- Notches are molded extra deep
- Oil and heat resistant
- Static conducting

Table No. 2

Belt No.	Length		Wt. Lbs.	Belt No.	Length		Wt. Lbs.
	Outside	Pitch			Outside	Pitch	
AX100	102.2"	101.3"	00.7	BX56	59.0"	57.8"	0.6
AX105	107.2	106.3	0.7	BX57	60.0	58.8	0.6
AX110	112.2	111.3	0.8	BX58	61.0	59.8	0.6
AX112	114.2	113.3	0.8	BX59	62.0	60.8	0.7
AX120	122.2	121.3	0.8	BX60	63.0	61.8	0.7
AX128	130.2	129.3	0.9	BX61	64.0	62.8	0.7
AX136	138.2	137.3	0.9	BX62	65.0	63.8	0.7
AX144	146.2	145.3	1.0	BX63	66.0	64.8	0.7
AX158	160.2	159.3	1.0	BX64	67.0	65.8	0.7
AX173	175.2	174.3	1.1	BX65	68.0	66.8	0.8
AX180	182.2	181.3	1.2	BX66	69.0	67.8	0.8
BX27	30.0	28.8	0.4	BX67	70.0	68.8	0.8
BX28	31.0	29.8	0.4	BX68	71.0	69.8	0.8
BX29	32.0	30.8	0.4	BX69	72.0	70.8	0.8
BX30	33.0	31.8	0.4	BX70	73.0	71.8	0.8
BX31	34.0	32.8	0.4	BX71	74.0	72.8	0.8
BX32	35.0	33.8	0.4	BX72	75.0	73.8	0.8
BX33	36.0	34.8	0.4	BX73	76.0	74.8	0.8
BX34	37.0	35.8	0.4	BX74	77.0	75.8	0.8
BX35	38.0	36.8	0.4	BX75	78.0	76.8	0.9
BX36	39.0	37.8	0.4	BX76	78.0	77.8	0.9
BX37	40.0	38.8	0.4	BX77	80.0	78.8	0.9
BX38	41.0	39.8	0.4	BX78	81.0	79.8	0.9
BX39	42.0	40.8	0.5	BX79	82.0	80.8	0.9
BX40	43.0	41.8	0.5	BX80	83.0	81.8	0.9
BX41	44.0	42.8	0.5	BX81	84.0	82.8	0.9
BX42	45.0	43.8	0.5	BX82	85.0	83.8	0.9
BX43	46.0	44.8	0.5	BX83	86.0	84.8	1.0
BX44	47.0	45.8	0.5	BX84	87.0	85.8	1.0
BX45	48.0	46.8	0.5	BX85	88.0	86.8	1.0
BX46	49.0	47.8	0.5	BX86	89.0	87.8	1.0
BX47	50.0	48.8	0.5	BX87	90.0	88.8	1.0
BX48	51.0	49.8	0.6	BX88	91.0	89.8	1.0
BX49	52.0	50.8	0.6	BX89	92.0	90.8	1.0
BX50	53.0	51.8	0.6	BX90	93.0	91.8	1.1
BX51	54.0	52.8	0.6	BX91	94.0	92.8	1.1
BX52	55.0	53.8	0.6	BX92	95.0	93.8	1.1
BX53	56.0	54.8	0.6	BX94	97.0	95.8	1.1
BX54	67.0	55.8	0.6	BX95	98.0	96.8	1.1
BX55	58.0	56.8	0.6	BX96	99.0	97.8	1.1



Gripnotch™ Belts

- Precision molded raw edge construction
- More horsepower in less space
- Notches are molded extra deep
- Oil and heat resistant
- Static conducting

Table No. 3

Belt No.	Length		Wt. Lbs.
	Outside	Pitch	
BX97	100.0"	98.8"	1.1
BX98	101.0	99.8	1.1
BX99	102.0	100.8	1.2
BX100	103.0	101.8	1.2
BX103	106.0	104.8	1.2
BX105	108.0	106.8	1.2
BX106	109.0	107.8	1.2
BX108	111.0	109.8	1.3
BX112	115.0	113.8	1.3
BX113	116.0	114.8	1.3
BX115	118.0	116.8	1.4
BX116	119.0	117.8	1.4
BX120	123.0	121.8	1.4
BX123	126.0	124.8	1.4
BX124	127.0	125.8	1.4
BX126	129.0	127.8	1.4
BX128	131.0	129.8	1.5
BX133	136.0	134.8	1.5
BX136	139.0	137.8	1.6
BX140	143.0	141.8	1.6
BX144	147.0"	145.8"	1.7
BX148	151.0	149.8	1.7
BX150	153.0	151.8	1.8
BX154	157.0	155.8	1.8
BX158	161.0	159.8	1.8
BX162	165.0	163.8	1.9
BX173	176.0	174.8	2.0
BX180	183.0	181.8	2.1
BX191	194.0	192.8	2.2
BX195	198.0	196.8	2.3
BX210	213.0	211.8	2.5
BX225	228.0	226.8	2.7
BX240	241.5	240.3	2.8
BX255	256.5	255.3	3.0
BX270	271.5	270.3	3.2
BX300	301.5	300.3	3.6
CX51	55.2	53.9	1.0
CX55	59.2	57.9	1.1
CX60	64.2	62.9	1.2
CX68	72.2	70.9	1.4



Gripnotch™ Belts

- Precision molded raw edge construction
- More horsepower in less space
- Notches are molded extra deep
- Oil and heat resistant
- Static conducting

Table No. 4

Belt No.	Length		Wt. Lbs.
	Outside	Pitch	
CX72	76.2"	74.9"	1.4
CX75	79.2	77.9	1.5
CX78	82.2	80.9	1.6
CX81	85.2	83.9	1.6
CX85	89.2	87.9	1.7
CX90	94.2	92.9	1.8
CX96	100.2	98.9	1.9
CX100	104.2	102.2	2.0
CX101	105.2	103.9	2.0
CX105	109.2	107.9	2.0
CX109	113.2	111.9	2.1
CX111	115.2	113.9	2.2
CX112	116.2	114.9	2.2
CX115	119.2	117.9	2.3
CX120	124.2	122.9	2.4
CX128	132.2	130.9	2.6
CX136	140.2	138.9	2.7
CX144	148.2	146.9	2.9
CX150	154.2	152.9	3.0
CX158	162.2	160.9	3.0
CX162	166.2	164.9	3.1
CX173	177.2	175.9	3.1
CX180	184.2	182.9	3.2
CX195	199.2	197.9	3.5
CX210	214.2	212.9	4.0
CX225	229.2	227.9	4.2
CX240	242.2	240.9	4.3
CX255	259.2	257.9	4.6
CX270	272.2	270.9	5.0
CX300	304.2	302.9	5.4
CX330	334.2	332.9	5.9
CX360	364.2	362.9	6.3
DX120	125.2	123.3	4.3
DX128	133.2	131.2	4.4
DX158	163.2	161.3	5.4
DX162	167.2	165.3	5.6
DX180	185.2	183.2	6.2
DX360	362.7	360.8	12.3



FHP Belts

- Wrapped construction provides smooth, quiet operation
- Formulated for maximum flexibility with smaller diameter sheaves
- Oil and heat resistant - static conducting

Table No. 1

Belt No.	Length		Wt. Lbs.	Belt No.	Length		Wt. Lbs.
	Outside	Pitch			Outside	Pitch	
2L120	12"	11.6"	0.03	3L380	38"	37.3"	0.12
2L140	14	13.6	0.04	3L390	39	38.3	0.12
2L150	15	14.6	0.04	3L400	40	39.3	0.13
2L160	16	15.6	0.04	3L410	41	40.3	0.13
2L180	18	17.6	0.05	3L420	42	41.3	0.13
2L200	20	19.6	0.06	3L430	43	42.3	0.13
2L220	22	21.6	0.06	3L440	44	43.3	0.14
2L240	24	23.6	0.07	3L450	45	44.3	0.14
2L285	28 1/2	28.1	0.07	3L460	46	45.3	0.14
2L300	30	29.6	0.08	3L470	47	46.3	0.15
2L310	31	30.6	0.08	3L480	48	47.3	0.15
2L320	32	31.6	0.09	3L490	49	48.3	0.15
2L325	32 1/2	32.1	0.09	3L500	50	49.3	0.16
2L345	34 1/2	34.1	0.09	3L510	51	50.3	0.16
3L120	12	11.3	0.04	3L520	52	51.3	0.16
3L130	13	12.3	0.04	3L530	53	52.3	0.17
3L140	14	13.3	0.05	3L540	54	53.3	0.17
3L150	15	14.3	0.05	3L550	55	54.3	0.18
3L160	16	15.3	0.05	3L560	56	55.3	0.18
3L170	17	16.3	0.05	3L570	57	56.3	0.18
3L180	18	17.3	0.06	3L580	58	57.3	0.18
3L190	19	18.3	0.06	3L590	59	58.3	0.19
3L200	20	19.3	0.06	3L600	60	59.3	0.19
3L210	21	20.3	0.07	3L610	61	60.3	0.19
3L220	22	21.3	0.07	3L620	62	61.3	0.19
3L230	23	22.3	0.07	3L630	63	62.3	0.2
3L240	24	23.3	0.08	4L170	17	16	0.1
3L250	25	24.3	0.08	4L180	18	17	0.1
3L260	26	25.3	0.08	4L190	19	18	0.11
3L270	27	26.3	0.08	4L200	20	19	0.11
3L280	28	27.3	0.09	4L210	21	20	0.12
3L290	29	28.3	0.09	4L220	22	21	0.12
3L300	30	29.3	0.09	4L225	22 1/2	21.5	0.13
3L310	31	30.3	.010	4L230	23	22	0.13
3L320	32	31.3	0.1	4L240	24	23	0.13
3L330	33	32.3	0.1	4L250	25	24	0.13
3L340	34	33.3	0.11	4L260	26	25	0.13
3L350	35	34.3	0.11	4L270	27	26	0.13
3L360	36	35.3	0.11	4L280	28	27	0.13
3L370	37	36.3	0.12	4L290	29	28	0.13



FHP Belts

- Wrapped construction provides smooth, quiet operation
- Formulated for maximum flexibility with smaller diameter sheaves
- Oil and heat resistant - static conducting

Table No. 2

Belt No.	Length		Wt. Lbs.	Belt No.	Length		Wt. Lbs.
	Outside	Pitch			Outside	Pitch	
4L300	30"	29"	0.13	4L690	69"	68"	0.38
4L310	31	30	0.19	4L700	70	69	0.38
4L320	32	31	0.19	4L710	71	70	0.38
4L330	33	32	0.19	4L720	72	71	0.38
4L340	34	33	0.19	4L730	73	72	0.38
4L350	35	34	0.19	4L740	74	73	0.38
4L360	36	35	0.19	4L750	75	74	0.44
4L370	37	36	0.19	4L760	76	75	0.44
4L380	38	37	0.19	4L770	77	76	0.44
4L390	39	38	0.25	4L780	78	77	0.44
4L400	40	39	0.25	4L790	79	78	0.44
4L410	41	40	0.25	4L800	80	79	0.44
4L415	41 1/2	40.5	0.25	4L810	81	80	0.44
4L420	42	41	0.25	4L820	82	81	0.44
4L430	43	42	0.25	4L830	83	82	0.44
4L440	44	43	0.25	4L840	84	83	0.44
4L450	45	44	0.25	4L850	85	84	0.5
4L460	46	45	0.25	4L860	86	85	0.5
4L470	47	46	0.25	4L870	87	86	0.5
4L480	48	47	0.25	4L880	88	87	0.5
4L490	49	48	0.31	4L890	89	88	0.5
4L500	50	49	0.31	4L900	90	89	0.5
4L510	51	50	0.31	4L910	91	90	0.5
4L520	52	51	0.31	4L920	92	91	0.5
4L530	53	52	0.31	4L930	93	92	0.5
4L540	54	53	0.31	4L940	94	93	0.5
4L550	55	54	0.31	4L950	95	94	0.5
4L560	56	55	0.31	4L960	96	95	0.5
4L570	57	56	0.31	4L970	97	96	0.5
4L580	58	57	0.31	4L980	98	97	0.56
4L590	59	58	0.31	4L990	99	98	0.56
4L600	60	59	0.31	4L1000	100	99	0.56
4L610	61	60	0.31	5L230	23	21.8	0.19
4L620	62	61	0.31	5L240	24	22.8	0.19
4L630	63	62	0.31	5L250	25	23.8	0.19
4L640	64	63	0.38	5L260	26	24.8	0.19
4L650	65	64.0	0.38	5L270	27	25.8	0.19
4L660	66	65	0.38	5L280	28	26.8	0.19
4L670	67	66	0.38	5L290	29	27.8	0.19
4L680	68	67	0.38	5L300	30	28.8	0.29



FHP Belts

- Wrapped construction provides smooth, quiet operation
- Formulated for maximum flexibility with smaller diameter sheaves
- Oil and heat resistant - static conducting

Table No. 3

Belt No.	Length		Wt. Lbs.
	Outside	Pitch	
5L310	31"	29.8"	0.25
5L320	32	30.8	0.25
5L330	33	31.8	0.25
5L340	34	32.8	0.25
5L350	35	33.8	0.31
5L360	36	34.8	0.31
5L370	37	35.8	0.31
5L380	38	36.8	0.31
5L390	39	37.8	0.31
5L400	40	38.8	0.31
5L410	41	39.8	0.38
5L420	42	40.8	0.38
5L430	43	41.8	0.38
5L440	44	42.8	0.38
5L450	45"	43.8	0.38
5L460	46	44.8	0.44
5L470	47	45.8	0.44
5L480	48	46.8	0.44
5L490	49	47.8	0.5
5L500	50	48.8	0.5
5L510	51	49.8	0.5
5L520	52	50.8	0.5
5L530	53	51.8	0.5
5L540	54	52.8	0.5
5L550	55	53.8	0.5
5L560	56	54.8	0.5
5L570	57	55.8	0.5
5L580	58	56.8	0.5
5L590	59	57.8	0.5
5L600	60	58.8	0.56
5L610	61	59.8	0.56
5L620	62	60.8	0.56
5L630	63	61.8	0.56
5L640	64	62.8	0.63
5L650	65	63.8	0.63
5L660	66	64.8	0.63
5L670	67	65.8	0.63
5L680	68	66.8	0.63
5L690	69	67.8	0.63
5L700	70	68.8	0.69

FHP Belts

- Wrapped construction provides smooth, quiet operation
- Formulated for maximum flexibility with smaller diameter sheaves
- Oil and heat resistant - static conducting

Table No. 4

Belt No.	Length		Wt. Lbs.
	Outside	Pitch	
5L710	71	69.8	0.69
5L720	72	70.8	0.69
5L730	73	71.8	0.69
5L740	74	72.8	0.69
5L750	75	73.8	0.69
5L760	76	74.8	0.69
5L770	77	75.8	0.69
5L780	78	76.8	0.75
5L790	79	77.8	0.75
5L800	80	78.8	0.75
5L810	81	79.8	0.75
5L820	82	80.8	0.75
5L830	83	81.8	0.75
5L840	84	82.8	0.75
5L850	85	83.8	0.81
5L860	86	84.8	0.81
5L870	87	85.8	0.81
5L880	88	86.8	0.81
5L890	89	87.8	0.81
5L900	90	88.8	0.81
5L910	91	89.8	0.88
5L920	92	90.8	0.88
5L930	93	91.8	0.88
5L940	94	92.8	0.88
5L950	95	93.8	0.88
5L960	96	94.8	0.88
5L970	97	95.8	0.88
5L980	98	96.8	0.94
5L990	99	97.8	0.94
5L1000	100	98.8	0.94



"358" Gripbelts® and Gripnotch™

Table No. 1

- Oil and heat resistant
- More horsepower in less space
- Static conducting

Part No.	Outside Length	Wt. Lbs.	Part No.	Outside Length	Wt. Lbs.	Part No.	Outside Length	Wt. Lbs.
3VX250	25.0	.1	5VX590	59.0	.6	5V2240	224.0	2.6
3VX265	26.5	.1	5VX600	60.0	.7	5V2360	236.0	2.8
3VX280	28.0	.1	5VX610	61.0	.7	5V2500	250.0	2.9
3VX300	30.0	.1	5VX630	63.0	.7	5V2650	265.0	3.2
3VX315	31.5	.1	5VX650	65.0	.7	5V2800	280.0	3.3
3VX335	33.5	.1	5VX660	66.0	.8	5V3000	300.0	3.6
3VX355	35.5	.2	5VX670	67.0	.8	5V3150	315.0	3.9
3VX375	37.5	.2	5VX680	68.0	.8	5V3350	335.0	4.0
3VX400	40.0	.2	5VX690	69.0	.8	5V3550	355.0	4.3
3VX425	42.5	.2	5VX710	71.0	.8			
3VX450	45.0	.2	5VX730	73.0	.8	8V1000	100.0	3.3
3VX475	47.0	.2	5VX740	74.0	.8	8V1120	112.0	3.6
3VX500	50.0	.2	5VX750	75.0	.8	8V1180	118.0	3.8
3VX530	53.0	.2	5VX780	78.0	.8	8vV1250	125.0	3.9
3VX560	56.0	.2	5VX800	80.0	.9	8V1320	132.0	4.3
3VX600	60.0	.3	5VX810	81.0	.9	8V1400	140.0	4.5
3VX630	63.0	.3	5VX830	83.0	.9	8V1500	150.0	4.8
3VX670	67.0	.3	5VX840	84.0	.9	8V1600	160.0	5.1
3VX710	71.0	.3	5VX850	85.0	.9	8V1700	170.0	5.6
3VX750	75.0	.3	5VX860	86.0	.9	8V1800	180.0	6.0
3VX800	80.0	.4	5VX880	88.0	.9	8V1900	190.0	6.3
3VX850	85.0	.4	5VX900	90.0	1.0	8V2000	200.0	6.5
3VX900	90.0	.4	5VX930	93.0	1.0	8V2120	212.0	6.9
3VX950	95.0	.4	5VX950	95.0	1.0	8V2240	224.0	7.2
3VX1000	100.0	.4	5VX960	96.0	1.0	8V2360	236.0	7.6
3VX1060	106.0	.4	5VX1000	100.0	1.1	8V2500	250.0	8.0
3VX1120	112.0	.5	5VX1030	103.0	1.1	8V2650	265.0	8.5
3VX1180	118.0	.5	5VX1060	106.0	1.2	8V2800	280.0	8.9
3VX1250	125.0	.6	5VX1080	108.0	1.2	8V3000	300.0	9.6
3VX1320	132.0	.6	5VX1120	112.0	1.3	8V3150	315.0	10.3
3VX1400	140.0	.6	5VX1150	115.0	1.3	8V3350	335.0	11.4
			5VX1180	118.0	1.4	8V3550	355.0	12.4
5VX450	45.0	.4	5VX1230	123.0	1.4	8V4000	400.0	13.0
5VX470	47.0	.5	5VX1250	125.0	1.4	8V4500	450.0	14.4
5VX490	49.0	.5	5VX1320	132.0	1.5			
5VX500	50.0	.6	5VX1400	140.0	1.6			
5VX510	51.0	.6	5VX1500	150.0	1.8			
5VX530	53.0	.6	5VX1600	160.0	1.8			
5VX540	54.0	.6	5VX1700	170.0	2.0			
5VX550	55.0	.6	5VX1800	180.0	2.1			
5VX560	56.0	.6	5VX1900	190.0	2.3			
5VX570	57.0	.6	5VX2000	200.0	2.4			
5VX580	58.0	.6	5V2120	212.0	2.4			



Belts Cross-Reference

4L, A, AX Belts - Cross-Reference

Table 1

4L	A	AX	Length	4L	A	AX	Length
4L230	A21	AX21	23.2	4L630	A61	AX61	63.2
4L240	A22	AX22	24.2	4L640	A62	AX62	64.2
4L250	A23	AX23	25.2	4L650	A63	AX63	65.2
4L260	A24	AX24	26.2	4L660	A64	AX64	66.2
4L270	A25	AX25	26.2	4L670	A65	AX65	67.2
4L280	A26	AX26	28.2	4L680	A66	AX66	68.2
4L290	A27	AX27	29.2	4L690	A67	AX67	69.2
4L300	A28	AX28	30.2	4L700	A68	AX68	70.2
4L310	A29	AX29	31.2	4L710	A69	AX69	71.2
4L320	A30	AX30	32.2	4L720	A70	AX70	72.2
4L330	A31	AX31	33.2	4L730	A71	AX71	73.2
4L340	A32	AX32	34.2	4L740	A72	AX72	74.2
4L350	A33	AX33	35.2	4L750	A73	AX73	75.2
4L360	A34	AX34	36.2	4L760	A74	AX74	76.2
4L370	A35	AX35	37.2	4L770	A75	AX75	77.2
4L380	A36	AX36	38.2	4L780	A76	AX76	78.2
4L390	A37	AX37	39.2	4L790	A77	AX77	79.2
4L400	A38	AX38	40.2	4L800	A78	AX78	80.2
4L410	A39	AX39	41.2	4L810	A79	AX79	81.2
4L420	A40	AX40	42.2	4L820	A80	AX80	82.2
4L430	A41	AX41	43.0	4L830	A81	AX81	83.2
4L440	A42	AX42	44.2	4L840	A82	AX82	84.2
4L450	A43	AX43	45.2	4L850	A83	AX83	85.2
4L460	A44	AX44	46.2	4L860	A84	AX84	86.2
4L470	A45	AX45	47.2	4L870	A85	AX85	87.2
4L480	A46	AX46	48.2	4L880	A86	AX86	88.2
4L490	A47	AX47	49.2	4L890	A87	AX87	89.2
4L500	A48	AX48	50.2	4L900	A88	AX88	90.2
4L510	A49	AX49	51.2	4L910	A89	AX89	91.2
4L520	A50	AX50	52.2	4L920	A90	AX90	92.2
4L530	A51	AX51	53.2	4L930	A91	AX91	93.2
4L540	A52	AX52	54.2	4L940	A92	AX92	94.2
4L550	A53	AX53	55.2	4L950	A93	AX93	95.2
4L560	A54	AX54	56.2	4L960	A94	AX94	96.2
4L570	A55	AX55	57.2	4L970	A95	AX95	97.2
4L580	A56	AX56	58.2	4L980	A96	AX96	98.2
4L590	A57	AX57	59.2	4L990	A97	AX97	99.2
4L600	A58	AX58	60.2	4L1000	A98	AX98	100.2
4L610	A59	AX59	61.2	-	A99	AX99	101.2
4L620	A60	AX60	62.2	-	A100	AX100	102.2

Substitutions can be made based on this chart only from left to right.

Example: 4L230 can be interchanged with an A21 or AX21, but the A21 can not be substituted for the AX21.



Belts Cross-Reference

5L, B, BX Belts - Cross-Reference

Table 1

5L	B	BX	Length	5L	B	BX	Length
5L310	B28	BX28	31.0	5L680	B65	BX65	68.0
5L320	B29	BX29	32.0	5L690	B66	BX66	69.0
5L330	B30	BX30	33.0	5L700	B67	BX67	70.0
5L340	B31	BX31	34.0	5L710	B68	BX68	71.0
5L350	B32	BX32	35.0	5L720	B69	BX69	72.0
5L360	B33	BX33	36.0	5L730	B70	BX70	73.0
5L370	B34	BX34	37.0	5L740	B71	BX71	74.0
5L380	B35	BX35	38.0	5L750	B72	BX72	75.0
5L390	B36	BX36	39.0	5L760	B73	BX73	76.0
5L400	B37	BX37	40.0	5L770	B74	BX74	77.0
5L410	B38	BX38	41.0	5L780	B75	BX75	78.0
5L420	B39	BX39	42.0	5L790	B76	BX76	79.0
5L430	B40	BX40	43.0	5L800	B77	BX77	80.0
5L440	B41	BX41	44.0	5L810	B78	BX78	81.0
5L450	B42	BX42	45.0	5L820	B79	B X79	82.0
5L460	B43	BX43	46.0	5L830	B80	BX80	83.0
5L470	B44	BX44	47.0	5L840	B81	BX81	84.0
5L480	B45	BX45	48.0	5L850	B82	BX82	85.0
5L490	B46	BX46	49.0	5L860	B83	BX83	86.0
5L500	B47	BX47	50.0	5L870	B84	BX84	87.0
5L510	B48	BX48	51.0	5L880	B85	BX85	88.0
5L520	B49	BX49	52.0	5L890	B86	BX86	89.0
5L530	B50	BX50	53.0	5L900	B87	BX87	90.0
5L540	B51	BX51	54.0	5L910	B88	BX88	91.0
5L550	B52	BX52	55.0	5L920	B89	BX89	92.0
5L560	B53	BX53	56.0	5L930	B90	BX90	93.0
5L570	B54	BX54	57.0	5L940	B91	BX91	94.0
5L580	B55	BX55	58.0	5L950	B92	BX92	95.0
5L590	B56	BX56	59.0	5L960	B93	BX93	96.0
5L600	B57	BX57	60.0	5L970	B94	BX94	97.0
5L610	B58	BX58	61.0	5L980	B95	BX95	98.0
5L620	B59	BX59	62.0	5L990	B96	BX96	99.0
5L630	B60	BX60	63.0	5L1000	B97	BX97	100.0
5L640	B61	BX61	64.0	-	B98	BX98	101.0
5L650	B62	BX62	65.0	-	B99	BX99	102.0
5L660	B63	BX63	66.0	-	B100	BX100	103.0
5L670	B64	BX64	67.0				

Substitutions can be made based on this chart only from left to right.

Example: 4L230 can be interchanged with an A21 or AX21, but the A21 can not be substituted for the AX21.

Browning®

A Complete Selection of Browning Products Leads to the Right V-Belt for Every Application

The Browning line offers the most extensive V-drive line available anywhere, which means maximum economy versatility and prompt availability for your every application...truly the *right* drive every time...for every service.

- **New combination groove B5V®** with 170 plus components covering 10-125 HP range. Mix and match with conventional A, B and 5V components.
- **Cast iron sheaves** over 3000 AK/BK size and bore combinations in stock, in-shaft ready bushing type and finished bore.
- **Variable speed sheaves** through 750 HP, precision balanced to provide smooth vibration-free performance.



B5V Sheaves



*Variable Speed Sheaves
VP, VL, VM*

*Cast Iron Sheaves
AK, 2AK, AKH, 2AKH
BK, 2BK, BKH, 2BKH*



"H" Bushing

Cast Iron Sheaves

Single Groove Sheaves for "4L" or "A" Belts
 "3L" belts may also be used with these sheaves as indicated in table below.

Table 1 Stock Sizes - Finished Bore

Part No.	DIAMETER			STOCK BORES MARKED "X"												Wt. Lbs.
	Outside	Datum "A"	Pitch "3L"	1/2"	5/8"	3/4"	7/8"	15/16"	1"	1 1/8"	1 3/16"	1 1/4"	1 3/8"	1 7/16"		
▲ AK17	1.75"	1.50"	1.16"	X	X	-	-	-	-	-	-	-	-	-	-	.2
▲ AK20	2.00	1.80	1.46	X	X	X	-	-	-	-	-	-	-	-	-	.3
▲ AK21	2.10	1.90	1.56	X	X	X	-	-	-	-	-	-	-	-	-	.4
▲ AK22	2.20	2.00	1.66	X	X	X	-	-	-	-	-	-	-	-	-	.5
▲ AK23	2.30	2.10	1.76	X	X	X	-	-	-	-	-	-	-	-	-	.5
▲ AK25	2.50	2.30	1.96	X	X	X	-	-	-	-	-	-	-	-	-	.5
▲ AK26	2.60	2.40	2.06	X	X	X	-	-	-	-	-	-	-	-	-	.5
▲ AK27	2.70	2.50	2.16	X	X	X	-	-	-	-	-	-	-	-	-	.6
▲ AK28	2.80	2.60	2.26	X	X	X	-	-	-	-	-	-	-	-	-	.7
▲ AK30	3.05	2.80	2.46	X	X	X	X	-	-	-	-	-	-	-	-	.7
▲ AK32	3.25	3.00	2.66	X	X	X	X	-	-	-	-	-	-	-	-	.7
▲ AK34	3.45	3.20	2.86	X	X	X	X	-	-	-	-	-	-	-	-	.9
AK39	3.75	3.50	3.16	X	X	X	X	X	X	-	-	-	-	-	-	1.4
AK41	3.95	3.70	3.36	X	X	X	X	X	X	X	-	-	-	-	-	1.5
AK44	4.25	4.00	3.66	X	X	X	X	X	X	X	X	-	-	-	-	1.5
AK46	4.45	4.20	3.86	X	X	X	X	X	X	X	X	-	-	-	-	1.5
AK49	4.75	4.50	4.16	X	X	X	X	X	X	X	X	-	-	-	-	1.7
AK51	4.95	4.70	4.36	X	X	X	X	X	X	X	X	-	-	-	-	1.7
AK54	5.25	5.00	4.66	X	X	X	X	X	X	X	X	X	-	-	-	1.8
AK56	5.45	5.20	4.86	X	X	X	X	X	X	X	X	X	X	-	-	1.9

▲Note - Do not use these "AK" sheaves with bores 1" and under with gripnotch™ belt ratings.

Cast Iron Sheaves

Single Groove Sheaves for "4L" or "A" Belts (continued)

"3L" belts may also be used with these sheaves as indicated in table below.

Table 1 Stock Sizes - Finished Bore (continued)

Part No.	DIAMETER			STOCK BORES MARKED "X"											Wt. Lbs.
	Outside	Datum "A"	Pitch "3L"	1/2"	5/8"	3/4"	7/8"	15/16"	1"	1 1/8"	1 3/16"	1 1/4"	1 3/8"	1 7/16"	
AK59	5.75	5.50	5.16	X	X	X	X	X	X	X	X	-	-	-	2.0
AK61	5.95	5.70	5.36	X	X	X	X	X	X	X	X	-	-	-	2.1
AK64	6.25	6.00	5.66	X	X	X	X	X	X	X	X	-	-	-	2.2
AK66	6.45	6.20	5.86	-	X	X	-	-	X	X	-	-	-	-	2.3
AK69	6.75	6.50	6.16	-	-	X	-	-	X	X	-	-	-	-	3.5
AK71	6.95	6.70	6.36	-	X	X	-	-	X	X	-	-	-	X	3.8
▲ AK74	7.25	7.00	6.66	X	X	X	-	-	X	X	X	X	-	X	3.4
▲ AK79	7.75	7.50	7.16	-	-	X	-	-	X	X	-	-	-	X	4.0
▲ AK84	8.25	8.00	7.66	X	X	X	-	-	X	X	-	-	-	X	3.8
▲ AK89	8.75	8.50	8.16	-	-	X	-	-	X	X	-	-	-	X	4.3
▲ AK94	9.25	9.00	8.66	X	X	X	-	-	X	X	X	X	-	X	4.5
▲ AK99	9.75	9.50	9.16	-	-	X	-	-	X	X	-	-	-	X	5.3
▲ AK104	10.25	10.00	9.66	-	X	X	-	-	X	X	X	X	X	X	5.1
▲ AK109	10.75	10.50	10.16	-	-	X	-	-	X	X	-	-	-	X	5.8
▲ AK114	11.25	11.00	10.66	-	-	X	-	-	X	X	-	-	-	X	5.6
▲ AK124	12.25	12.00	11.66	-	X	X	-	-	X	X	X	X	X	X	6.5
AK134	13.25	13.00	12.66	-	-	X	-	-	X	X	-	-	-	X	7.5
AK144	14.25	14.00	13.66	-	-	X	-	-	X	X	-	-	-	X	8.5
AK154	15.25	15.00	14.66	-	-	X	-	-	X	X	-	-	X	X	9.8
AK184	18.25	18.00	17.66	-	-	X	-	-	X	X	-	-	-	X	12.1

▲ Note - Do not use these "AK" sheaves with bores 1" and under with gripnotch™ belt ratings.

Cast Iron Sheaves

Two Groove Sheaves for "4L" or "A" Belts
 "3L" belts may also be used with these sheaves as indicated in table below.

Table 1 Stock Sizes - Finished Bore

Part No.	DIAMETER		STOCK BORES MARKED "X"										Wt. Lbs.		
	Outside	Datum "A"	Pitch "3L"	1/2"	5/8"	3/4"	7/8"	15/16"	1"	1 1/8"	1 3/16"	1 3/8"		1 7/16"	
2AK20	2.00"	1.80"	1.46"	X	X	X	-	-	-	-	-	-	-	-	.8
2AK21	2.15	1.90	1.56	X	X	X	-	-	-	-	-	-	-	-	.9
2AK22	2.25	2.00	1.66	X	X	X	X	-	-	-	-	-	-	-	.9
2AK23	2.35	2.10	1.76	-	X	X	X	-	X	-	-	-	-	-	1.1
2AK25	2.55	2.30	1.96	-	X	X	X	-	X	-	-	-	-	-	1.3
2AK26	2.65	2.40	2.06	-	X	X	X	-	X	-	-	-	-	-	1.4
2AK27	2.75	2.50	2.16	-	X	X	X	-	X	-	-	-	-	-	1.5
2AK28	2.85	2.60	2.26	-	X	X	X	-	X	-	-	-	-	-	1.8
2AK30	3.05	2.80	2.46	X	X	X	X	-	X	X	-	-	-	-	1.8
2AK32	3.25	3.00	2.66	-	X	X	X	-	X	X	-	-	-	-	2.1
2AK34	3.45	3.20	2.86	-	X	X	X	-	X	X	-	-	-	-	2.3
2AK39	3.75	3.50	3.16	-	X	X	X	-	X	X	-	-	-	-	2.6
2AK41	3.95	3.70	3.36	-	X	X	X	-	X	X	-	-	-	-	2.9
2AK44	4.25	4.00	3.66	-	X	X	X	-	X	X	-	-	-	-	3.0
2AK46	4.45	4.20	3.86	-	-	-	X	-	X	X	-	-	-	-	3.1
2AK49	4.75	4.50	4.16	-	-	X	X	-	X	X	-	X	-	-	3.6

Cast Iron Sheaves

Two Groove Sheaves for "4L" or "A" Belts (continued)

"3L" belts may also be used with these sheaves as indicated in table below.

Table 1 Stock Sizes - Finished Bore (continued)

Part No.	DIAMETER		STOCK BORES MARKED "X"										Wt. Lbs.		
	Outside	Datum "A"	Pitch "3L"	1/2"	5/8"	3/4"	7/8"	15/16"	1"	1 1/8"	1 3/16"	1 3/8"		1 7/16"	
2AK51	4.95	4.70	4.36	-	-	X	X	-	X	-	-	X	-	-	3.8
2AK54	5.25	5.00	4.66	-	X	X	X	-	X	-	-	X	-	-	3.3
2AK56	5.45	5.20	4.86	-	X	X	-	-	X	-	-	X	-	-	3.4
2AK59	5.75	5.50	5.16	-	-	-	-	-	X	-	-	X	-	-	3.5
2AK61	5.95	5.70	5.36	-	-	X	X	-	X	-	-	X	-	-	3.6
2AK64	6.25	6.00	5.66	-	-	X	-	-	X	-	X	X	X	X	4.8
2AK74	7.25	7.00	6.66	-	-	X	-	-	X	-	X	X	X	X	5.6
2AK84	8.25	8.00	7.66	-	-	X	-	X	X	-	X	X	X	X	6.4
2AK94	9.25	9.00	8.66	-	-	X	-	-	X	-	X	X	X	X	7.3
2AK104	10.25	10.00	9.66	-	-	X	-	X	X	-	-	-	X	X	8.1
2AK114	11.25	11.00	10.66	-	-	X	-	-	X	-	X	X	X	X	9.0
2AK124	12.25	12.00	11.66	-	-	X	-	-	X	-	X	-	X	X	9.8
2AK134	13.25	13.00	12.66	-	-	-	-	-	-	-	X	-	X	X	12.3
2AK144	14.25	14.00	13.66	-	-	-	-	-	-	X	-	-	X	X	13.9
2AK154	15.25	15.00	14.66	-	-	-	-	-	-	-	X	-	X	X	14.3
2AK184	18.25	18.00	17.66	-	-	-	-	-	-	-	-	-	X	X	17.4

Cast Iron Sheaves

Single Groove Sheaves for "4L" or "A" Belts

"3L" belts may be used with these sheaves as indicated in table below.

Table 1 Stock Sizes - with Split Taper Bushings

Part No.	DIAMETER			Wt. Less Bush
	O.D.	Datum "A"	Pitch "3L"	
AK30H	3.05"	2.80"	2.46"	1.1
AK32H	3.25	3.00	2.66	1.2
AK34H	3.45	3.20	2.86	1.0
AK39H	3.75	3.50	3.16	1.4
AK41H	3.95	3.70	3.36	1.6
AK44H	4.25	4.00	3.66	1.9
AK46H	4.45	4.20	3.86	1.9
AK49H	4.75	4.50	4.16	2.1
AK51H	4.95	4.70	4.36	2.3
AK54H	5.25	5.00	4.66	2.0
AK56H	5.45	5.20	4.86	2.3
AK59H	5.75	5.50	5.16	2.4
AK61H	5.95	5.70	5.36	2.5
AK64H	6.25	6.00	5.66	2.7
AK66H	6.45	6.20	5.86	2.8
AK69H	6.75	6.50	6.16	3.2
AK71H	6.95	6.70	6.36	3.1
AK74H	7.25	7.00	6.66	3.3
AK79H	7.75	7.50	7.16	3.5
AK84H	8.25	8.00	7.66	3.6
AK89H	8.75	8.50	8.16	4.0
AK94H	9.25	9.00	8.66	4.4
AK99H	9.75	9.50	9.16	4.7
AK104H	10.25	10.00	9.66	4.5
AK109H	10.75	10.50	10.16	5.1
AK114H	11.25	11.00	10.66	5.5
AK124H	12.25	12.00	11.66	6.1
AK134H	13.25	13.00	12.66	7.4
AK144H	14.25	14.00	13.66	7.8
AK154H	15.25	15.00	14.66	8.8
AK184H	18.25	18.00	17.66	11.3

Table 2 Stock "H" Bushings

Inch Bore		Millimeter Bore		Stock Spline Bores	
Stock Bores	Keyseat	Stock Bores	Keyseat	Stock Bores	Keyseat
3/8", 7/16	None	10 mm	None	.978 - 10 Inv.	X
1/2, 9/16	1/8" x 1/16"	11, 12	None	1 1/8 - 6B	X
5/8, 11/16, 3/4	3/16 x 3/32	14	5 mm x 2.5 mm	1 3/8 - 6B	X
13/16, 7/8, 15/16	3/16 x 3/32	16	5 x 2.5	1 3/8 - 21 Inv.	X
1, 1 11/16	1/4 x 1/8	18, 19, 20, 22	6 x 3		
1 1/8, 1 3/16	1/4 x 1/8	24, 25, 28, 30	8 x 3.5		
1 1/4	1/4 x 1/16*	32, 35, 36, 38	10 x 4		
1 5/16, 1 3/8	5/16 x 1/16*				
1 3/8, 1 7/16, 1 1/2	3/8 x 1/16*				

Part numbers are specified by "H" and bore size. Example: "H-1 1/8"

*These sizes are furnished with special keys to fit standard depth keyseats.

Cast Iron Sheaves

Two Groove Sheaves for "4L" or "A" Belts (continued)

"3L" belts may be used with these sheaves as indicated in table below.

Table 1 Stock Sizes - with Split Taper Bushings

Part No.	DIAMETER			Wt. Less Bush
	O.D.	Datum "A"	Pitch "3L"	
2AK30H	3.05"	2.80"	2.46"	1.4
2AK32H	3.25	3.00	2.66	1.7
2AK34H	3.45	3.20	2.86	1.8
2AK39H	3.75	3.50	3.16	1.8
4AK41H	3.95	3.70	3.36	1.9
2AK44H	4.25	4.00	3.66	2.4
2AK46H	4.45	4.20	3.86	2.5
2AK49H	4.75	4.50	4.16	3.1
2AK51H	4.95	4.70	4.36	3.2
2AK54H	5.25	5.00	4.66	3.4
2AK56H	5.45	5.20	4.86	3.6
2AK59H	5.75	5.50	5.16	3.4
2AK61H	5.95	5.70	5.36	3.3
2AK64H	6.25	6.00	5.66	3.9
2AK74H	7.25	7.00	6.66	4.9
2AK84H	8.25	8.00	7.66	5.8
2AK94H	9.25	9.00	8.66	6.1
2AK104H	10.25	10.00	9.66	7.7
2AK114H	11.25	11.00	10.66	8.5
2AK124H	12.25	12.00	11.66	9.5
2AK134H	13.25	13.00	12.66	11.4
2AK144H	14.25	14.00	13.66	11.9
2AK154H	15.25	15.00	14.66	13.3
2AK184H	18.25	18.00	17.66	16.8

Table 2 Stock "H" Bushings

Inch Bore		Millimeter Bore		Stock Spline Bores	
Stock Bores	Keyseat	Stock Bores	Keyseat	Stock Bores	Keyseat
3/8", 7/16	None	10 mm	None	.978 - 10 Inv.	X
1/2, 9/16	1/8" x 1/16"	11, 12	None	1 1/8 - 6B	X
5/8, 11/16, 3/4	3/16 x 3/32	14, 16	5 mm x 2.5 mm	1 3/8 - 6B	X
13/16, 7/8	3/16 x 3/32	18, 19, 20, 22	6 x 3	1 3/8 - 21 Inv.	X
15/16, 1, 1 11/16	1/4 x 1/8	24, 25, 28, 30	8 x 3.5		
1 1/8, 1 3/16	1/4 x 1/8	32, 35, 36, 38	10 x 4		
1 1/4	1/4 x 1/16*				
1 5/16, 1 3/8	5/16 x 1/16*				
1 3/8, 1 7/16, 1 1/2	3/8 x 1/16*				

Part numbers are specified by "H" and bore size. Example: "H-1 1/8"

*These sizes are furnished with special keys to fit standard depth keyseats.

Cast Iron Sheaves

Single Groove Sheaves Combination Groove for "4L" or "A" Belts and "5L" or "B" Belts

Table 1 Stock Sizes - Finished Bore

Part No.	DIAMETER				STOCK BORES MARKED "X"												Wt. Lbs.
	Outside	Datum "A"	Datum "B"		1/2"	5/8"	3/4"	7/8"	15/16"	1"	1 1/8"	1 3/16"	1 1/4"	1 3/8"	1 7/16"		
▲BK24	2.40"	1.80"	2.20"		X	X	X	X	-	-	-	-	-	-	-	.4	
▲BK25	2.50	1.90	2.30		X	X	X	X	-	-	-	-	-	-	-	.5	
▲BK26	2.60	2.00	2.40		X	X	X	X	-	-	-	-	-	-	-	.6	
▲BK27	2.70	2.10	2.50		X	X	X	X	-	-	-	-	-	-	-	.6	
▲BK28	2.95	2.20	2.60		X	X	X	X	-	-	-	-	-	-	-	.8	
▲BK30	3.15	2.40	2.80		X	X	X	X	-	-	-	-	-	-	-	.8	
▲BK32	3.35	2.60	3.00		X	X	X	X	-	-	-	-	-	-	-	.8	
BK34	3.55	2.80	3.20		X	X	X	X	-	X	X	-	-	-	-	1.3	
BK36	3.75	3.00	3.40		X	X	X	X	-	X	X	-	-	-	-	1.5	
BK40	3.95	3.20	3.60		X	X	X	X	-	X	X	-	-	-	-	1.5	
BK45	4.25	3.50	3.90		X	X	X	X	-	X	X	-	-	-	-	1.8	
BK47	4.45	3.70	4.10		X	X	X	X	-	X	X	-	-	-	-	1.9	
BK50	4.75	4.00	4.40		X	X	X	X	X	X	X	-	-	-	-	2.0	
BK52	4.95	4.20	4.60		X	X	X	X	-	X	X	-	-	-	-	2.0	
BK55	5.25	4.50	4.90		X	X	X	X	-	X	X	X	-	-	-	2.2	
BK57	5.45	4.70	5.10		-	X	X	X	X	X	X	-	-	-	-	2.3	
BK60	5.75	5.00	5.40		X	X	X	X	-	X	X	X	-	-	-	2.3	
BK62	5.95	5.20	5.60		X	X	X	X	X	X	X	X	-	-	-	2.4	
BK65	6.25	5.50	5.90		-	X	X	X	-	X	X	-	-	-	-	2.7	

▲Note - Do not use these "BK" sheaves with "B" gripnotch™ belt ratings.

Cast Iron Sheaves

Single Groove Sheaves (continued) Combination Groove for "4L" or "A" Belts and "5L" or "B" Belts

Table 1 Stock Sizes - Finished Bore (continued)

Part No.	DIAMETER			STOCK BORES MARKED "X"												Wt. Lbs.
	Outside	Datum "A"	Datum "B"	1/2"	5/8"	3/4"	7/8"	15/16"	1"	1 1/8"	1 3/16"	1 1/4"	1 3/8"	1 7/16"		
BK67	6.45	5.70	6.10	-	X	X	-	-	X	X	-	-	-	-	2.8	
BK70	6.75	6.00	6.40	-	X	X	-	X	X	X	X	-	-	X	3.3	
BK72	6.95	6.20	6.60	-	-	X	-	-	X	X	-	-	X	-	3.9	
BK75	7.25	6.50	6.80	-	-	X	-	-	X	X	-	-	X	-	3.9	
BK77	7.45	6.70	7.10	-	-	X	-	-	X	X	-	-	X	-	4.1	
BK80	7.75	7.00	7.40	-	X	X	X	-	X	X	X	X	X	X	4.4	
BK85	8.25	7.50	7.90	-	-	X	-	-	X	X	-	-	X	X	5.0	
BK90	8.75	8.00	8.40	-	-	X	X	-	X	X	-	-	X	X	5.0	
BK95	9.25	8.50	8.90	-	-	X	-	-	X	X	-	-	X	X	5.4	
BK100	9.75	9.00	9.40	-	-	X	X	-	X	X	X	X	X	X	5.6	
BK105	10.25	9.50	9.90	-	-	-	-	-	X	X	-	-	X	X	5.8	
BK110	10.75	10.00	10.40	-	-	X	-	-	X	X	X	-	X	X	6.4	
BK115	11.25	10.50	10.90	-	-	-	-	-	X	X	-	-	X	X	6.9	
BK120	11.75	11.00	11.40	-	-	X	-	-	X	X	-	-	X	X	7.4	
BK130	12.75	12.00	12.40	-	-	X	-	-	X	X	X	X	-	X	8.4	
BK140	13.75	13.00	13.40	-	-	X	-	-	X	X	X	-	-	X	9.4	
BK160	15.75	15.00	15.40	-	-	-	-	-	X	X	X	X	-	X	11.4	
BK190	18.75	18.00	18.40	-	-	-	-	-	X	X	X	X	-	X	13.4	

▲Note - Do not use these "BK" sheaves with "B" gripnotch™ belt ratings.

Cast Iron Sheaves

Two Groove Sheaves Combination Groove for "4L" or "A" Belts and "5L" or "B" Belts

Table 1 Stock Sizes - Finished Bore

Part No.	DIAMETERS		STOCK BORES MARKED "X"										Wt. Lbs.	
	Outside	Datum A"	Datum B"	1/2"	5/8"	3/4"	7/8"	1"	1 1/8"	1 3/16"	1 3/8"	1 7/16"		
2BK25	2.50"	1.90"	2.30"	X	X	X	X	-	-	-	-	-	-	1.3
2BK27	2.70	2.10	2.50	X	X	X	X	X	-	-	-	-	-	1.6
2BK28	2.95	2.20	2.60	X	X	X	X	X	X	-	-	-	-	1.9
2BK30	3.15	2.40	2.80	X	X	X	X	X	X	-	-	-	-	2.3
2BK32	3.35	2.60	3.00	-	X	-	X	X	X	-	-	-	-	2.6
2BK34	3.55	2.80	3.20	-	X	-	X	X	X	-	X	-	-	2.8
2BK36	3.75	3.00	3.40	-	X	-	X	X	X	-	X	-	-	3.3
2BK40	3.95	3.20	3.60	-	X	-	X	X	X	-	X	-	-	3.3
2BK45	4.25	3.50	3.90	-	-	-	X	X	X	-	X	-	-	3.7
2BK47	4.45	3.70	4.10	-	-	-	X	X	X	-	X	-	-	4.1
2BK50	4.75	4.00	4.40	-	-	X	-	X	X	-	X	-	-	4.5
2BK52	4.95	4.20	4.60	-	-	-	X	X	X	-	X	-	-	4.5
2BK55	5.25	4.50	4.90	-	-	-	-	X	X	-	X	-	-	5.1
2BK57	5.45	4.70	5.10	-	-	-	X	X	X	-	X	-	-	4.9
2BK60	5.75	5.00	5.40	-	-	X	-	X	X	-	X	-	-	4.8
2BK62	5.95	5.20	5.60	-	-	-	-	X	X	-	X	-	-	5.0
2BK65	6.25	5.50	5.90	-	-	-	-	X	X	-	X	-	-	6.6
2BK67	6.45	5.70	6.10	-	-	-	-	X	X	-	X	-	-	7.2
2BK70	6.75	6.00	6.40	-	-	X	-	X	X	-	X	-	-	8.4
2BK80	7.75	7.00	7.40	-	-	X	-	X	X	-	X	-	-	9.4
2BK90	8.75	8.00	8.40	-	-	X	-	X	X	-	X	-	-	10.4
2BK100	9.75	8.75	8.4	-	-	X	-	X	X	-	X	-	-	11.8
2BK110	10.75	10.00	10.40	-	-	-	-	X	X	-	X	-	-	14.9
2BK120	11.75	11.00	11.40	-	-	-	-	X	X	-	X	-	-	16.3
2BK130	12.75	12.00	12.40	-	-	-	-	X	X	-	X	-	-	18.0
2BK140	13.75	13.00	13.40	-	-	-	-	X	X	-	X	-	-	23.3
2BK160	15.75	15.00	15.40	-	-	-	-	X	X	-	X	-	-	
2BK190	18.75	18.00	18.40	-	-	-	-	X	X	-	X	-	-	

Cast Iron Sheaves

Single Groove Sheaves Combination Groove for "4L" or "A" Belts and "5L" or B" Belts

Table 1 Stock Sizes - with Split Taper Bushings

Part No.	DIAMETER			Wt. Lbs. Less Bush.
	O.D.	Datum "A"	Datum "B"	
BK30H	3.15"	2.40"	2.80"	1.2
BK32H	3.35	2.60	3.00	1.4
BK34H	3.55	2.80	3.20	1.6
BK36H	3.75	3.00	3.40	1.2
BK40H	3.95	3.20	3.60	1.4
BK45H	4.25	3.50	3.90	1.8
BK47H	4.45	3.70	4.10	2.2
BK50H	4.75	4.00	4.40	2.0
BK52H	4.95	4.20	4.60	2.1
BK55H	5.25	4.50	4.90	2.7
BK57H	5.45	4.70	5.10	2.7
BK60H	5.75	5.00	5.40	2.5
BK62H	5.95	5.20	5.60	2.6
BK65H	6.25	5.50	5.90	2.8
BK67H	6.45	5.70	6.10	2.9
BK70H	6.75	6.00	6.40	2.8
BK72H	6.95	6.20	6.60	3.1
BK75H	7.25	6.50	6.90	3.3
BK77H	7.45	6.70	7.10	3.8
BK80H	7.75	7.00	7.40	3.4
BK85H	8.25	7.50	7.90	3.8
BK90H	8.75	8.00	8.40	4.3
BK95H	9.25	8.50	8.90	5.0
BK100H	9.75	9.00	9.40	5.2
BK105H	10.25	9.50	9.90	5.5
BK110H	10.75	10.00	10.40	6.0
BK115H	11.25	10.50	10.90	6.4
BK120H	11.75	11.00	11.40	6.9
BK130H	12.75	12.00	12.40	6.9
BK140H	13.75	13.00	13.40	8.5
BK150H	14.75	14.00	14.40	9.5
BK160H	15.75	15.00	15.40	9.8
BK190H	18.75	18.00	18.40	12.8

Table 2 Stock "H" Bushings

Inch Bore		Millimeter Bore		Stock Spline Bores	
Stock Bores	Keyseat	Stock Bores	Keyseat	Stock Bores	Keyseat
3/8", 7/16	None	10 mm	None	.978 - 10 Inv.	X
1/2, 9/16	1/8" x 1/16"	11, 12	None	1 1/8 - 6B	X
5/8, 11/16, 3/4	3/16 x 3/32	14, 16	5 mm x 2.5 mm	1 3/8 - 6B	X
13/16, 7/8	3/16 x 3/32	18, 19, 20, 22	6 x 3	1 3/8 - 21 Inv.	X
15/16, 1, 1 11/16	1/4 x 1/8	24, 25, 28, 30	8 x 3.5		
1 1/8, 1 3/16	1/4 x 1/8	32, 35, 36, 38	10 x 4		
1 1/4	1/4 x 1/16*				
1 5/16, 1 3/8	5/16 x 1/16*				
1 3/8, 1 7/16, 1 1/2	3/8 x 1/16*				

Part numbers are specified by "H" and bore size. Example: "H-1 1/8"

*These sizes are furnished with special keys to fit standard depth keyseats.

Cast Iron Sheaves

**Two Groove Sheaves
Combination Groove
for "4L" or "A" Belts and "5L" or B" Belts**

Table 1 Stock Sizes - with Split Taper Bushings

Part No.	DIAMETER			Wt. Lbs.
	O.D.	Datum "A"	Datum "B"	Less Bush.
2BK32H	3.35"	2.60"	3.00"	2.1
2BK34H	3.55	2.80	3.20	2.4
2BK36H	3.75	3.00	3.40	2.0
2BK40H	3.95	3.20	3.60	2.4
2BK45H	4.25	3.50	3.90	3.0
2BK47H	4.45	3.70	4.10	2.8
2BK50H	4.75	4.00	4.40	3.3
2BK52H	4.95	4.20	4.60	3.6
2BK55H	5.25	4.50	4.90	3.9
2BK57H	5.45	4.70	5t.10	4.3
2BK60H	5.75	5.00	5.40	4.4
2BK62H	5.95	5.20	5.60	4.5
2BK65H	6.25	5.50	5.90	4.5
2BK67H	6.45	5.70	6.10	5.0
2BK70H	6.75	6.00	6.40	5.1
2BK80H	7.75	7.00	7.40	6.4
2BK90H	8.75	8.00	8.40	7.6
2BK100H	9.75	9.00	9.40	8.4
2BK110H	10.75	10.00	10.40	9.3
2BK120H	11.75	11.00	11.40	11.0
2BK130H	12.75	12.00	12.40	13.1
2BK140H	13.75	13.00	13.40	14.8
2BK160H	15.75	15.00	15.40	17.5
2BK190H	18.75	18.00	18.40	21.5

Table 2 Stock "H" Bushings

Inch Bore		Millimeter Bore		Stock Spline Bores	
Stock Bores	Keyseat	Stock Bores	Keyseat	Stock Bores	Keyseat
3/8", 7/16	None	10 mm	None	.978 - 10 Inv.	X
1/2, 9/16	1/8" x 1/16"	11, 12	None	1 1/8 - 6B	X
5/8, 11/16, 3/4	3/16 x 3/32	14, 16	5 mm x 2.5 mm	1 3/8 - 6B	X
13/16, 7/8	3/16 x 3/32	18, 19, 20, 22		6 x 3	1 3/8 - 21 Inv.
15/16, 1, 1 11/16	1/4 x 1/8	24, 25, 28, 30	8 x 3.5		
1 1/8, 1 3/16	1/4 x 1/8	32, 35, 36, 38	10 x 4		
1 1/4	1/4 x 1/16*				
1 5/16, 1 3/8	5/16 x 1/16*				
1 3/8, 1 7/16, 1 1/2	3/8 x 1/16*				

Part numbers are specified by "H" and bore size. Example: "H-1 1/8"

*These sizes are furnished with special keys to fit standard depth keyseats.



Stock Sheave Interchange

Sheaves for "4L", "A", "5L" or B" Belts

4L or A	5L or B	Browning	Other Manufacturers			
			Maurey*	T. B. Wood's*	Dodge*	Maska*
2.4	2.8	BK 30H	-	HB 31 QT	BK 30H	MBL 31
2.6	3.0	BK 32H	-	HB 33 QT	BK 32H	MBL 33
2.8	3.2	BK 34H	-	HB 35 QT	BK 34H	MBL 35
3.0	3.4	BK 36H	-	HB 37 QT	BK 36H	MBL 37
3.2	3.6	BK 40H	BH 40	HB 39 QT	BK 40H	MBL 39
3.5	3.9	BK 45H	BH 42	HB 42 QT	BK 45H	MBL 42
3.7	4.1	BK 47H	BH 44	HB 44 QT	BK 47H	MBL 44
-	-	BK 49H	BH 48	HB 47 QT	BK 49H	MBL 47
4.2	4.6	BK 52H	BH 50	HB 49 QT	BK 52H	MBL 49
4.5	4.9	BK 55H	BH 52	HB 52 QT	BK 55H	MBL 52
4.7	5.1	BK 57H	BH 54	HB 54 QT	BK 57H	MBL 54
5.0	5.4	BK 60H	BH 58	HB 57 QT	BK 60H	MBL 57
5.2	5.6	BK 62H	BH 60	HB 59 QT	BK 62H	MBL 59
5.5	5.9	BK 65H	BH 66	HB 62 QT	BK 65H	MBL 62
5.7	6.1	BK 67H	BH 68	HB 64 QT	BK 67H	MBL 64
6.0	6.4	BK 70H	BH 70	HB 67 QT	BK 70H	MBL 67
6.2	6.6	BK 72H	BH 72	HB 69 QT	BK 72H	MBL 69
6.5	6.9	BK 75H	-	HB 72 QT	BK 75H	MBL 72
6.7	7.1	BK 77H	-	HB 74 QT	BK 77H	MBL 74
7.0	7.4	BK 80H	BH 78	HB 77 QT	BK 80H	MBL 77
7.5	7.9	BK 85H	-	HB 82 QT	BK 85H	MBL 82
8.0	8.4	BK 90H	-	HB 87 QT	BK 90H	MBL 87
8.5	8.9	BK 95H	-	HB 92 QT	BK 95H	MBL 92
9.0	9.4	BK 100H	BH 98	HB 97 QT	BK 100H	MBL 97
9.5	9.9	BK 105H	-	HB 102 QT	BK 105H	MBL 102
10.0	10.4	BK 110H	BH 108	HB 107 QT	BK 110H	MBL 107
10.5	10.9	BK 115H	-	HB 112 QT	BK 115H	MBL 112
16.0	11.4	BK 120H	BH 118	HB 117 QT	BK 120H	MBL 117
12.0	12.4	BK 130H	BH 128	HB 127 QT	BK 130H	MBL 127
13.0	13.4	BK 140H	-	HB 137 QT	BK 140H	MBL 137
15.0	15.4	BK 160H	BH 158	HB 157 QT	BK 160H	MBL 157
18.0	18.4	BK 190H	BH 188	HB 187 QT	BK 190H	MBL 187

*Maurey is a trademark of Maurey Manufacturing Corporation. *TB Wood's is a trademark of TB Wood's Incorporated. *Dodge is a trademark of Reliance Electric Company. *Maska is a trademark of Maska Inc.

These trade names, trademarks and/or registered trademarks of others are used herein for product comparison purposes only, are the property of their respective owner and are not owned or controlled by Emerson Power Transmission Corporation. Emerson Power Transmission does not represent or warrant the accuracy of this document.

Gripbelt® Sheaves with Split Taper Bushings

Specifications - Stock "B5V®" Sheaves

Part Number	Bushing	DIAMETERS					Wt. (lbs.) Less Bush.
		Datum "A" Belts	Datum "B" Belts	Pitch "5V" Belts	Outside		
1 GROOVE, F = 1							
1B5V42	P1	3.8	4.2	4.3	4.48	2.5	
1B5V44	P1	4.0	4.4	4.5	4.68	2.8	
1B5V46	B	4.2	4.6	4.7	4.88	2.5	
1B5V48	B	4.4	4.8	4.9	5.08	2.9	
1B5V50	B	4.6	5.0	5.1	5.28	3.3	
1B5V52	B	4.8	5.2	5.3	5.48	3.7	
1B5V54	B	5.0	5.4	5.5	5.68	4.1	
1B5V56	B	5.2	5.6	5.7	5.88	4.5	
1B5V58	B	5.4	5.8	5.9	6.08	5.0	
1B5V60	B	5.6	6.0	6.1	6.28	5.4	
1B5V62	B	5.8	6.2	6.3	6.48	5.3	
1B5V64	B	6.0	6.4	6.5	6.68	5.6	
1B5V66	B	6.2	6.6	6.7	6.88	6.0	
1B5V68	B	6.4	6.8	6.9	7.08	6.4	
1B5V70	B	6.6	7.0	7.1	7.28	6.8	
1B5V74	B	7.0	7.4	7.5	7.68	7.7	
1B5V80	B	7.6	8.0	8.1	8.28	7.5	
1B5V86	B	8.2	8.6	8.7	8.88	7.9	
1B5V90	B	8.6	9.0	9.1	9.28	8.2	
1B5V94	B	9.0	9.4	9.5	9.68	8.5	
1B5V110	B	10.6	11.0	11.1	11.28	10.3	
1B5V124	B	12.0	12.4	12.5	12.68	11.5	
1B5V136	B	13.2	13.6	13.7	13.88	13.3	
1B5V154	B	15.0	15.4	15.5	15.68	15.5	
1B5V160	B	15.6	16.0	16.1	16.28	16.6	
1B5V184	B	18.0	18.4	18.5	18.68	20.0	
1B5V200	B	19.5	20.0	20.1	20.28	21.8	
1B5V234	B	22.9	23.4	23.5	23.68	28.2	
1B5V250	B	24.5	25.0	25.1	25.28	31.4	
1B5V278	B	27.3	27.8	27.9	28.08	36.5	

Gripbelt® Sheaves with Split Taper Bushings

Specifications - Stock "B5V®" Sheaves - continued

Part Number	Bushing	DIAMETERS				Wt. (lbs.) Less Bush.
		Datum "A" Belts	Datum "B" Belts	Pitch "5V" Belts I	Outside	
2 GROOVE, F = 1 23/32						
2B5V42	P1	3.8	4.2	4.3	4.48	3.7
2B5V44	P1	4.0	4.4	4.5	4.68	4.1
2B5V46	B	4.2	4.6	4.7	4.88	3.3
2B5V48	B	4.4	4.8	4.9	5.08	3.9
2B5V50	B	4.6	5.0	5.1	5.28	4.6
2B5V52	B	4.8	5.2	5.3	5.48	5.3
2B5V54	B	5.0	5.4	5.5	5.68	6.0
2B5V56	B	5.2	5.6	5.7	5.88	6.7
2B5V58	B	5.4	5.8	5.9	6.08	7.4
2B5V60	B	5.6	6.0	6.1	6.28	8.2
2B5V62	B	5.8	6.2	6.3	6.48	9.2
2B5V64	B	6.0	6.4	6.5	6.68	8.4
2B5V66	B	6.2	6.6	6.7	6.88	11.4
2B5V68	B	6.4	6.8	6.9	7.08	10.2
2B5V70	B	6.6	7.0	7.1	7.28	12.3
2B5V74	B	7.0	7.4	7.5	7.68	14.2
2B5V80	B	7.6	8.0	8.1	8.28	11.3
2B5V86	B	8.2	8.6	8.7	8.88	10.6
2B5V90	B	8.6	9.0	9.1	9.28	11.1
2B5V94	B	9.0	9.4	9.5	9.68	11.6
2B5V110	B	10.6	11.0	11.1	11.28	14.4
2B5V124	B	12.0	12.4	12.5	12.68	17.1
2B5V136	B	13.2	13.6	13.7	13.88	19.3
2B5V154	B	15.0	15.4	15.5	15.68	23.2
2B5V160	B	15.6	16.0	16.1	16.28	24.2
2B5V184	B	18.0	18.4	18.5	18.68	33.2
2B5V200	B	19.5	20.0	20.1	20.28	34.8
2B5V234	B	22.9	23.4	23.5	23.68	37.9
2B5V250	B	24.5	25.0	25.1	25.28	47.0
2B5V278	B	27.3	27.8	27.9	28.08	55.9

Gripbelt® Sheaves with Split Taper Bushings

Specifications - Stock "B5V®" Sheaves - continued

Part Number	Bushing	Diameters				Wt. (lbs.) Less Bush.
		Datum "A" Belts	Datum "B" Belts	Pitch "5V" Belts	Outside	
3 GROOVE, F = 27/16						
3B5V42	P1	3.8	4.2	4.3	4.48	4.8
3B5V44	P1	4.0	4.4	4.5	4.68	5.2
3B5V46	B	4.2	4.6	4.7	4.88	4.9
3B5V48	B	4.4	4.8	4.9	5.08	5.5
3B5V50	B	4.6	5.0	5.1	5.28	6.1
3B5V52	B	4.8	5.2	5.3	5.48	6.7
3B5V54	B	5.0	5.4	5.5	5.68	7.4
3B5V56	B	5.2	5.6	5.7	5.88	8.4
3B5V58	B	5.4	5.8	5.9	6.08	9.5
3B5V60	B	5.6	6.0	6.1	6.28	10.6
3B5V62	B	5.8	6.2	6.3	6.48	9.8
3B5V64	B	6.0	6.4	6.5	6.68	10.5
3B5V66	B	6.2	6.6	6.7	6.88	10.4
3B5V68	B	6.4	6.8	6.9	7.08	10.9
3B5V70	B	6.6	7.0	7.1	7.28	11.5
3B5V74	B	7.0	7.4	7.5	7.68	12.6
3B5V80	B	7.6	8.0	8.1	8.28	14.2
3B5V86	B	8.2	8.6	8.7	8.88	13.7
3B5V90	B	8.6	9.0	9.1	9.28	14.5
3B5V94	B	9.0	9.4	9.5	9.68	17.0
3B5V110	B	10.6	11.0	11.1	11.28	19.8
3B5V124	B	12.0	12.4	12.5	12.68	22.1
3B5V136	B	13.2	13.6	13.7	13.88	24.9
3B5V154	B	15.0	15.4	15.5	15.68	30.4
3B5V160	B	15.6	16.0	16.1	16.28	31.7
3B5V184	B	18.0	18.4	18.5	18.68	40.9
3B5V200	B	19.5	20.0	20.1	20.28	47.6
3B5V234	B	22.9	23.4	23.5	23.68	61.5
3B5V250	B	24.5	25.0	25.1	25.28	66.6
3B5V278	B	27.3	27.8	27.9	28.08	79.1

Gripbelt® Sheaves with Split Taper Bushings

Specifications - Stock "B5V®" Sheaves - continued

Part Number	Bushing	DIAMETERS				Wt. (lbs.) Less Bush.
		Datum "A" Belts	Datum "B" Belts	Pitch "5V" Belts	Outside	
4 GROOVE, F = 3 5/32						
4B5V42	P1	3.8	4.2	4.3	4.48	5.9
4B5V44	P1	4.0	4.4	4.5	4.68	6.3
4B5V46	B	4.2	4.6	4.7	4.88	6.1
4B5V48	B	4.4	4.8	4.9	5.08	6.7
4B5V50	B	4.6	5.0	5.1	5.28	7.4
4B5V52	B	4.8	5.2	5.3	5.48	8.0
4B5V54	B	5.0	5.4	5.5	5.68	8.9
4B5V56	B	5.2	5.6	5.7	5.88	9.5
4B5V58	B	5.4	5.8	5.9	6.08	10.3
4B5V60	B	5.6	6.0	6.1	6.28	11.0
4B5V62	B	5.8	6.2	6.3	6.48	11.3
4B5V64	B	6.0	6.4	6.5	6.68	12.1
4B5V66	B	6.2	6.6	6.7	6.88	12.0
4B5V68	B	6.4	6.8	6.9	7.08	12.6
4B5V70	B	6.6	7.0	7.1	7.28	13.2
4B5V74	B	7.0	7.4	7.5	7.68	14.5
4B5V80	B	7.6	8.0	8.1	8.28	15.2
4B5V86	B	8.2	8.6	8.7	8.88	16.6
4B5V90	B	8.6	9.0	9.1	9.28	17.6
4B5V94	B	9.0	9.4	9.5	9.68	20.0
4B5V110	B	10.6	11.0	11.1	11.28	22.8
4B5V124	B	12.0	12.4	12.5	12.68	26.5
4B5V136	B	13.2	13.6	13.7	13.88	30.7
4B5V154	B	15.0	15.4	15.5	15.68	37.9
4B5V160	B	15.6	16.0	16.1	16.28	40.5
4B5V184	B	18.0	18.4	18.5	18.68	50.7
4B5V200	B	19.5	20.0	20.1	20.28	58.5
4B5V234	B	22.9	23.4	23.5	23.68	73.9
4B5V250	B	24.5	25.0	25.1	25.28	83.8
4B5V278	B	27.3	27.8	27.9	28.08	94.3

Variable Pitch Cast Iron Sheaves

Single Groove Variable Pitch Sheaves for "3L", "4L", "5L", "A", "B", and "5V" Belts

Table 1 Stock Sizes - Finished Bore (inches)

Part No.	OZ.	Stock Bores Marked "X"										WL Lbs.		
		1/2	5/8	3/4	7/8	1	1 1/8	1 1/4	1 3/8	1 5/8				
1VP25	2.50	-	-	-	-	-	-	-	-	-	-	-	-	0.8
1P30	2.87	X	X	X	-	-	-	-	-	-	-	-	-	0.9
1VP34	3.15	X	X	X	X	-	-	-	-	-	-	-	-	1.2
1P40	375	X	X	X	X	-	-	-	-	-	-	-	-	17
1VP44	4.15	X	X	X	-	-	-	-	-	-	-	-	-	1.9
1VP44	4.15	-	-	-	X	-	-	-	X	-	-	-	-	2.6
1VP50	475	X	X	X	-	-	-	-	-	-	-	-	-	1.9
1VP50	475	-	-	-	X	-	-	-	X	-	-	-	-	2.9
1VP56	5.35	X	X	X	-	-	-	-	-	-	-	-	-	27
1VP56	5.35	-	-	-	X	-	-	-	X	-	-	-	-	3.4
1VP60	6.00	-	-	X	X	-	-	-	X	-	-	X	X	5.5
1VP62	5.95	-	X	X	X	X	-	-	X	X	-	X	-	57
1VP65	6.50	-	-	X	X	-	-	-	X	-	-	X	X	5.8
1VP68	6.55	-	X	X	X	X	-	-	X	X	-	X	*	6.4
1VP71	7.10	-	-	X	X	-	-	-	X	-	-	X	X	6.8
1VP75	7.50	-	-	X	X	-	-	-	X	-	-	X	X	7.3

Variable Pitch Cast Iron Sheaves

Single Groove Variable Pitch Sheaves for
 “3L”, “4L”, “5L”, “A”, “B”, and “5V” Belts

Table 2

Part No.	DIAMETER RANGE																							
	“3L” BELTS						“4L” or “A” BELTS						“5L” OR “B” BELTS						“5V” BELTS					
	Min. Pitch		Turns Open		Max. Pitch		Min. Pitch		Turns Open		Max. Pitch		Min. Pitch		Turns Open		Max. Pitch		Min. Pitch		Turns Open		Max. Pitch	
	Open	Turns	Open	Turns	Open	Turns	Open	Turns	Open	Turns	Open	Turns	Open	Turns	Open	Turns	Open	Turns	Open	Turns	Open	Turns	Open	Turns
1VP25	1.6	4	2.4	0	-	-	-	-	-	-	-	-	-	-	-	-	-	-	-	-	-	-	-	-
1VP30	1.8	4	2.7	0	-	-	-	-	-	-	-	-	-	-	-	-	-	-	-	-	-	-	-	-
1VP34	1.7	4	2.5	0	2.0	5	3.0	0	2.5	5	3.3	1	2.5	5	3.3	1	2.5	5	3.3	1	2.5	5	3.3	1
1VP40	2.3	4	3.1	0	2.6	5	3.6	0	2.8	6	3.8	1	2.8	6	3.8	1	2.8	6	3.8	1	2.8	6	3.8	1
1VP44	2.7	4	3.5	0	3.0	5	4.0	0	3.2	6	4.2	1	3.2	6	4.2	1	3.2	6	4.2	1	3.2	6	4.2	1
1VP44	2.7	4	3.5	0	3.0	5	4.0	0	3.2	6	4.2	1	3.2	6	4.2	1	3.2	6	4.2	1	3.2	6	4.2	1
1VP50	3.3	4	4.1	0	3.6	5	4.6	0	3.8	6	4.8	1	3.8	6	4.8	1	3.8	6	4.8	1	3.8	6	4.8	1
1VP50	3.3	4	4.1	0	3.6	5	4.6	0	3.8	6	4.8	1	3.8	6	4.8	1	3.8	6	4.8	1	3.8	6	4.8	1
1VP56	3.9	4	4.7	0	4.2	5	5.2	0	4.4	6	5.4	1	4.4	6	5.4	1	4.4	6	5.4	1	4.4	6	5.4	1
1VP56	3.9	4	4.7	0	4.2	5	5.2	0	4.4	6	5.4	1	4.4	6	5.4	1	4.4	6	5.4	1	4.4	6	5.4	1
1VP60	-	-	-	-	4.4	5	5.4	0	4.7	6	5.9	0	4.7	6	5.9	0	4.7	6	5.9	0	4.7	6	5.9	0
1VP62	-	-	-	-	4.4	5	5.4	0	4.7	6	5.9	0	4.7	6	5.9	0	4.7	6	5.9	0	4.7	6	5.9	0
1VP65	-	-	-	-	4.9	5	5.9	0	5.2	6	6.4	0	5.2	6	6.4	0	5.2	6	6.4	0	5.2	6	6.4	0
1VP68	-	-	-	-	4.9	5	5.9	0	5.2	6	6.4	0	5.2	6	6.4	0	5.2	6	6.4	0	5.2	6	6.4	0
1VP71	-	-	-	-	5.5	5	6.5	0	5.8	6	7.0	0	5.8	6	7.0	0	5.8	6	7.0	0	5.8	6	7.0	0
1VP75	-	-	-	-	5.9	5	6.9	0	6.2	6	7.4	0	6.2	6	7.4	0	6.2	6	7.4	0	6.2	6	7.4	0

Variable Pitch Cast Iron Sheaves

Two Groove Variable Pitch Sheaves for "3L", "4L", "5L", "A", "B", and "5V" Belts

Table 1 Stock Sizes - Finished Bore (inches)

Part No.	O.D.	Stock Bore Sizes Marked "X"										Wt. Lbs.			
		1/2	5/8	3/4	7/8	1	1 1/8	1 1/4	1 3/8	1 5/8	1 3/4				
2VP36	3.35	X	X	X	X	-	-	-	-	-	-	-	-	-	2.6
2VP42	3.95	-	X	X	X	X	X	X	X	X	X	X	X	X	3.5
2VP50	4.75	-	X	X	X	X	X	X	X	X	X	X	X	X	5.4
2VP56	5.35	-	X	X	X	X	X	X	X	X	X	X	X	X	6.6
2VP60	6.00	-	-	X	X	X	X	X	X	X	X	X	X	X	10.2
2VP62	5.95	-	-	X	X	X	X	X	X	X	X	X	X	X	10.5
2VP65	6.50	-	-	X	X	X	X	X	X	X	X	X	X	X	11.6
2VP68	6.55	-	-	-	X	X	X	X	X	X	X	X	X	X	12.3
2VP71	7.10	-	-	X	X	X	X	X	X	X	X	X	X	X	13.4
2VP75	7.50	-	-	X	X	X	X	X	X	X	X	X	X	X	15.5

Variable Pitch Cast Iron Sheaves

Two Groove Variable Pitch Sheaves for "3L", "4L", "5L", "A", "B", and "5V" Belts

Table 2

Part No.	DIAMETER RANGE																							
	"3L" BELTS						"4L" or "A" BELTS						"5L" OR "B" BELTS						"5V" BELTS					
	Min. Pitch	Turns Open	Max. Pitch	Turns Open	Min. Pitch	Turns Open	Max. Pitch	Turns Open	Min. Pitch	Turns Open	Max. Pitch	Turns Open	Min. Pitch	Turns Open	Max. Pitch	Turns Open	Min. Pitch	Turns Open	Max. Pitch	Turns Open				
2VP36	1.9	4	2.7	0	2.2	5	3.2	0	2.6	5	3.4	1	-	-	-	-	-	-	-	-				
2VP42	2.5	4	3.3	0	2.8	5	3.8	0	3.0	6	4.0	1	-	-	-	-	-	-	-	-				
2VP50	3.3	4	4.1	0	3.6	5	4.6	0	3.8	6	4.8	1	-	-	-	-	-	-	-	-				
2VP56	3.9	4	4.7	0	4.2	5	5.2	0	4.4	6	5.4	1	-	-	-	-	-	-	-	-				
2VP60	-	-	-	-	4.4	5	5.4	0	4.7	6	5.9	0	4.7	-	5.9	-	4.7	-	5.9	-				
2VP62	-	-	-	-	4.4	5	5.4	0	4.7	6	5.9	1	4.7	6	5.9	6	4.7	6	5.9	0				
2VP65	-	-	-	-	4.9	5	5.9	0	5.2	6	6.4	0	5.2	6	6.4	6	5.2	6	6.4	0				
2VP68	-	-	-	-	4.9	5	5.9	0	5.2	6	6.4	1	5.2	6	6.4	6	5.2	6	6.4	0				
2VP71	-	-	-	-	5.5	5	6.5	0	5.8	6	7.0	0	5.8	6	7.0	6	5.8	6	7.0	0				
2VP75	-	-	-	-	5.9	5	6.9	0	6.2	6	7.4	0	6.2	6	7.4	6	6.2	6	7.4	0				

All fitted with hollow head setscrews

Any standard two groove Browning sheave can be used as a companion sheave.

Variable Pitch Cast Iron Sheaves

Table 1 Stock "VL" and "VM" Variable Pitch Sheaves

Part No.	O.D.	Stock Bores Marked "X"				Wt. Lbs.
		1/2	5/8	3/4	7/8	
1VL25	2.50	X	X	-	-	-
1VL30	2.87	X	X	-	-	0.9
1VL34	3.15	X	X	X	-	1.2
1VL40	3.75	X	X	X	X	1.7
1VL44	4.15	X	X	X	X	1.9
1VM50	4.75	X	X	X	X	1.9

Table 2

Part No.	DIAMETER RANGE											
	"3L" BELTS				"4L" or "A" BELTS				"5L" OR "B" BELTS			
	Min. Pitch	Turns Open	Max. Pitch	Turns Open	Min. Pitch	Turns Open	Max. Pitch	Turns Open	Min. Pitch	Turns Open	Max. Pitch	Turns Open
1VL25	1.6	4	2.4	0	-	-	-	-	-	-	-	-
1VL30	1.8	4	2.7	0	-	-	-	-	-	-	-	-
1VL34	1.7	4	2.5	0	2.0	5	3.0	0	2.5	5	3.3	1
1VL40	2.3	4	3.1	0	2.6	5	3.6	0	2.8	6	3.8	1
1VL44	2.7	4	3.5	0	3.0	5	4.0	0	3.2	6	4.2	1
1VM50	3.3	4	4.1	0	3.6	5	4.6	0	3.8	6	4.8	1

Split Taper Bushings



Bushing Specifications

Part No.	Dimensions		Bore Range		Cap Screws		Av. Wt Lbs..	Wrench Torque In-Lbs.
	D		Type 1	Type 2	No.	Size		
	Large End	Small End						
G	1.172"	1.133"	3/8" - 15/16	1	2	1/4 x 5/8	0.5	95
H	1.625	1.570	3/8-1 3/8	1 7/16-1 1/2	2	1/4 x 3/4	0.8	95
P1	1.938	1.856	1/2 - 1 7/16	1 1/2 - 1 3/4	3	5/16 x 1	1.3	192
P2	1.938	1.793	3/4 - 1 7/16	1 1/2 - 1 3/4	3	5/16 x 1	1.5	192
P3	1.938	1.699	11/8- 1 3/8	1 5/8	3	5/16 x 1	2	192
B	2.625	2.557	1/2 - 1 15/16	2 2/7/1916	3	5/16 x 1 1/4	1.8	192
Q1	2.875	2.766	3/4 - 2 1/16	2 1/8 - 2 11/16	3	3/8 x 1 1/4	3.5	348
Q2	2.875	2.703	1/21/1916	2 1/8 - 2 5/8	3	3/8 x 1 1/4	4.5	348
Q3	2.875	2.609	1 3/8 - 1/16	2 1/8 - 2 1/2	3	3/8 x 1 1/4	5.5	348
R1	2.875	3.875	1 1/8 - 2 13/16	2 7/8 - 3 3/4	3	3/8 x 1 3/4	7.5	348
R2	4.000	3.750	1 3/8 - 2 13/16	2 7/8 - 3 5/8	3	3/8 x 1 3/4	11	348
S1	4.000	4.418	1 11/16 - 3 3/16	3 1/4 - 4 1/4	3	1/2 x 2 1/4	13.5	840
S2	4.625	4.270	1 7/16 - 3 3/16	3 1/4 - 4 3/16	3	1/2 x 2 1/4	19	840
U0	4.625	5.766	2 3/8-3 1/16	□	3	5/8 x 2 3/4	30	1680
U1	6.000	5.766	3 1/4 - 4 1/4	4 3/8 - 5 1/2	3	5/8 x 2 3/4	27	1680
U2	6.000	5.649	2 3/8 - 4 1/4	4 3/8 - 5 1/2	3	5/8 x 2 3/4	40	1680
U2	6.000	5.461	2 7/16 - 4 1/4	4 3/8 - 5	3	5/8 x 2 3/4	50	1680
W1	6.000	8.102	3 3/8 - 6 3/16	6 1/4 - 7 7/16	4	3/4 x 3	104	3000
W2	8.500	7.914	3 3/8 - 6 3/16	6 1/4 - 7 7/16	4	3/4 x 3	133	3000
Y0*	8.500	11.469	6 - 7 15/16	8 - 0	4	1 x 5	270	7200

R1 - 1 1/8, R1- 1 3/16, R2 - 1 3/8, S1 - 1 11/16, S1 - 1 3/4, and S2 - 1 7/8" to 2 1/8" bushings are steel. U0 and U1 - 2 3/8" to 3 3/16" and U2 - 2 7/16" to 3 3/16" are cast iron. "W" and "Y" bushings are cast iron. All other bushings on this page are either sintered steel, malleable iron or ductile iron.

Contact factory for clarification.

Note: Taper on all Browning bushings is 3/4" per foot on diameter.

*Y bushings are made-to-order.

Bearings

Air Handling Solutions

Browning[®]



1000/1100 Series
Spherical Roller Bearing



Mounted Ball
Bearing

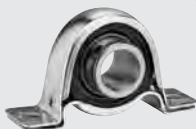

Stamped Steel
Bearing



22500 Series
Spherical Roller Bearing



Rubber
Mounted Bearing

Index

Page

Mounted Ball Bearings	102
Mounted Roller Bearings	103
Stamped Steel/Rubber Mount Bearings	104
Air Handling Applications.....	105
Air Handling Solutions	106 - 107
Locking Solutions	108 - 109
Mounting Installation.....	110 - 113
Bearing Basics and FAQs.....	114
Lubrication FAQs	115 - 116
Air Handling Interchange.....	117
Visit our online resources	118

Mounted Ball Bearings

- Available in a variety of housing configurations including pillow block, two-bolt flange, four-bolt flange and more
- Semi-solid cast iron base
- Anti-rotation rivet
- Available in set screw, eccentric and concentric (BOA) locking
- AH suffix product designates special air handling housing fit and noise testing



Mounted Roller Bearings - Spherical

- Available in a variety of housing configurations including pillow blocks, flange blocks, flange cartridges and take-up units
- Standard with Multi-Trap® seals
- Self-aligning, double-row spherical bearings
- One-piece cast iron (1000 Series) or ductile iron (1100 Series) housings



- Cast iron units in 22500 Series
- Tapered adapter locking mechanism
- Triple labyrinth seals
- Self-aligning, double-row spherical roller
- Removeable housing caps

Stamped Steel/Rubber Mounted

Rubber Mounted

- Available in cartridges and stamped steel pillow blocks
- Designed to fit into HVAC web-mount supports
- Cartridges adjust with misalignment and dampen noise and vibration



Stamped Steel

- Low cost, stamped steel housings for light-duty HVAC requirements
- Well suited for small spaces
- Permanently sealed and lubricated for life for maintenance-free operation



Air Handling Bearing Applications

	Light Duty	Light Commercial Duty	Commercial Duty	Industrial Duty
Browning® Ball	✓	✓	✓	✓
Browning 1000 Series			✓	✓
Browning 22500 Series				✓
Browning Runbber Mount	✓	✓		
Browning Stamped Steel	✓	✓		

Misalignment

Bearing Type	Misalignment
Ball	+/- 1 1/2°
Spherical Roller	+/- 1 1/2°

Housing Fits (Ball)

- Browning® ball bearings are manufactured with a special air handling housing fit
- Allows bearings to properly self-align when mounted on HVAC framing, which will in turn reduce vibration, excessive noise and possible bearing performance problems

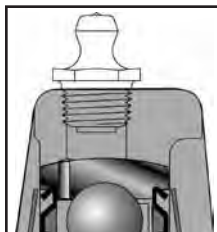

Precision Hardened and Honed Rings (Ball)

- Inner rings are zone hardened to maintain ballpath hardness while keeping the inner ring extension soft for greater lock reliability
- Ballpaths are honed for quieter operation and less vibration

Anti-Rotation Rivet (Ball)

- Prevents outer ring creep (rotation within the housing)
- Reduces heat build-up and prolongs useful bearing life

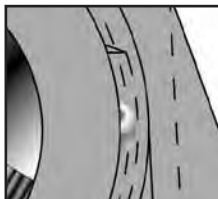

Air Handling Bearing Solutions

Noise Tested (Ball)

- Extra noise test check point added to manufacturing to ensure that bearings meet the exacting noise level needs of the air handling industry

Semi-Solid Cast Iron Base (Ball & Roller)

- Excellent mounting foundation
- Integral to preventing sheet metal “buckling”

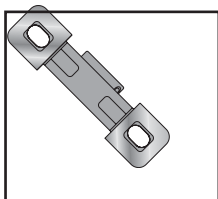

Stock Product (Ball)

- Specially designed “air-handling” bearings are a stock product and available off-the-shelf

Air Handling Locking Solutions

Setscrew Locking

- Most popular locking mechanism
- Does not require collar
- Easy to install
- Good for reversing applications



Inner Ring Roundness

- 120° Setscrew positioning
- 120° positioning gives less distortion than 90° or 45° set screw positioning, which is typically found on competitive products

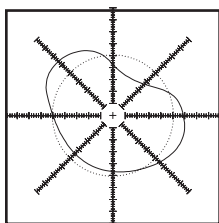

Air Handling Locking Solutions

BOA Concentric Lock

- Available on Browning ball bearings only
- High locking reliability
- Inner ring and collar system
- “Off-the-shelf” availability in popular AH bearing pillow block sizes 3/4" to 2 7/16"

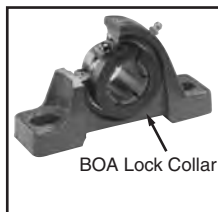

Inner Ring Roundness

- BOA locking collar minimizes ballpath distortion

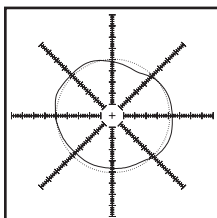

Eccentric Lock

- Eccentric locking collar mates with bearing inner race for shaft hold
- Lock collar bore and bearing inner race move in an offsetting direction from the lock collar creating a tight clamping force
- Lock collar surfaces are black oxide processed for corrosion protection
- Eccentric locking collars are **not recommended for reversing applications**



Setscrew Mounting Installation

Double and Single Setscrew Locking

1. Inspect Shaft

- Clean/remove burrs
- Check diameter
- Clean mounting surface
- Mounting surfaces must be flat



2. Place Bearing on Shaft

- Do not hammer bearing into shaft
- Apply light film of oil on shaft

3. Bolt Housing to Support Surface

- Bearing and shaft must be in alignment (see Misalignment table on page 104)
- Turn shaft to make sure that it rotates easily/smoothly

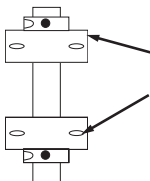
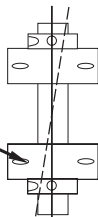

4. Align Setscrews on Either End of Shaft

5. Alternate Torquing of Setscrews (Table 1 Page 111)

- Step 1 - Torque setscrew "A" to half recommended torque
- Step 2 - Torque setscrew "B" to recommended torque
- Step 3 - Torque setscrew "A" to recommended torque
- Double Locking - repeat on opposite end

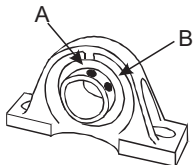

6. Start Equipment Slowly

- Check for unusual noise, vibration or bearing operating temperature during first 48 hours of operation

BOA Mounting Installation

1. Inspect Shaft

- Clean/remove burrs
- Check diameter
- Clean mounting surface
- Mounting surfaces must be flat



2. Place Bearing on Shaft

- Do not hammer bearing into shaft

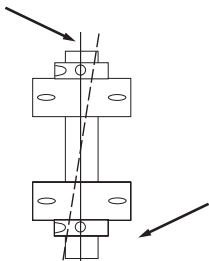

3. Bolt Housing to Support Surface

- Bearing and shaft must be in alignment $\pm 1.5^\circ$
- Turn shaft to make sure that it rotates

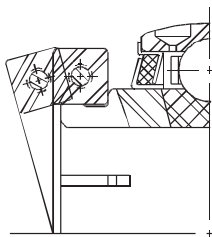

4. Push Locking Collar Tightly Against Inner Ring Shoulder

5. Torque Cap Screw to Recommended Value (Table 2 Page 111)

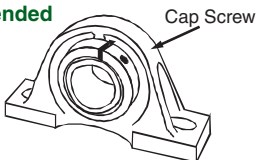

6. Start Equipment Slowly

- Check for unusual noise, vibration or bearing operating temperature during first 48 hours of operation

Eccentric Mounting Installation

1. Inspect Shaft

- Clean/remove burrs
- Check diameter
- Clean mounting surface
- Mounting surfaces must be flat



2. Place Bearing on Shaft

- Do not hammer bearing into shaft
- Apply light film of oil on shaft

3. Bolt Housing to Support Surface

- Bearing and shaft must be in alignment
 - Ball - 1 1/2° max
- Turn shaft to make sure that it rotates

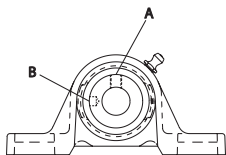
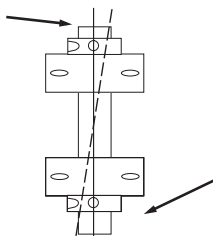

4. Fasten Unit to Shaft (See torque specification table)

- Step 1 - Place collar on inner race and rotate by hand in direction of shaft rotation until eccentrics are engaged
- Step 2 - Insert drift pin into the hole in the collar O.D. and lock in the direction of shaft rotation with aid of a small hammer
- Step 3 - Torque single setscrew to recommended torque (ref. Table 1 page 111)

5. Start Equipment Slowly

- Check for unusual noise, vibration or bearing operating temperature

Installation Engineering Tables

**Table 1 Torque for Tightening Setscrews
Setscrew, Double and Eccentric Locking Collars**

Setscrew Diameter	Hex Size Across Flats	Recommended Torque	
		Inch lbs	Foot lbs
1/4	1/8	66 - 85	5.5 - 7.2
5/16	5/32	126 - 164	10.5- 13.7
3/8	3/16	228 - 296	19.0 - 24.7
7/16	7/32	348 - 452	29.0- 37.7
1/2	1/4	504 - 655	42.0 - 54.6
5/8	5/16	1104 - 1435	92.0 - 119.6

**Table 2 Torque for Tightening Setscrews
BOA Locking Collars**

Cap Screw Size	Hex Wrench Size	Torq Wrench Size	Recommended Torque	
			Inch lbs	Foot lbs
#8-32 UNC-3A	1/8	T-25	65 - 70	7 - 8
#10-24 UNC-3A	9/64	T-27	90 - 100	10 - 11
#1/4-20 UNC-3A	3/16	T-30	220 - 240	25 - 27
#5/16-18 UNC-3A	1/4	T-45	450 - 495	51 - 56

Table 3 Recommended Shaft Tolerances

Nominal Shaft Diameter	Shaft Tolerance (inches)
1/2 - 1 15/16	+0.0000 / -0.0005
2 - 3 3/16	+0.0000 / -0.0010
3 1/4 - 4 15/16	+0.0000 / -0.0015

Bearing Basics and FAQs

	Speed Capability	Radial Load Capability	Thrust Load Capability	Misalignment
Ball Bearings	High	Moderate	Moderate	Static
Spherical Roller Bearings	Moderate	High	Low	Static and Dynamic
E-Type Tapered Roller Bearings	Low	High	High	None

Which can carry more radial load, a ball bearing or roller bearing?

- Roller bearings can carry more load because the rolling element has line contact with the raceway while the ball has only point contact
- Line contact means the load is spread out over a greater area, reducing the stress on races and rolling elements

Which type of bearing has the highest speed capability (ball, spherical or tapered roller bearing)?

- Ball bearings in general have the highest speed capability followed by spherical and tapered roller
- Larger contact areas (tapered roller bearings) result in higher levels of friction, which decreases speed capability

What is the difference between static and dynamic misalignment?

- Static misalignment = shaft misalignment at a constant angle with respect to the bearing
- Dynamic misalignment = shaft that is continuously misaligning with respect to the bearing

Bearing Lubrication FAQs

What is grease?

- Mixture of a soap/thickener, an oil and additives
- The thickener's function is to retain oil in the bearing cavity
- The oil provides lubricity to the rolling elements and raceways of the bearing
- Additives such as rust preventatives can enhance grease characteristics

Why grease instead of oil in the bearing?

- Grease is preferred due to reduced maintenance and/or lower cost
- Grease is easier to store, handle and transport
- Most mounted bearings are designed for relubrication with grease
- Oil is the preferred lubricant in high-speed or high-temperature applications

Can I mix greases?

- Compatibility may be an issue when mixing thickener and oil types
- Incompatibility can be avoided by using the grease or grease type recommended by the manufacturer

Can I over grease a bearing?

- Excessive grease in the bearing may be an issue for high speed applications
- Initial start-up after relubrication should be slow to allow grease to purge
- When greasing, add grease slowly
- Many mounted bearing seals are designed to allow grease to purge
- Some seals can be damaged or blown out by excessive relubrication

How often should I regrease, and how much grease should I add?

- The engineering charts in the engineering sections of the catalogs serve as general schedules since applications vary greatly. Your experience may be important in determining a lubrication schedule.

Lubrication Engineering Tables

Table 4 Ball Bearing Relubrication

Speed	Temperature	Cleanliness	Greasing Intervals
100 RPM	-20°F - 120°F	Clean	4 to 10 months
500 RPM	-20°F - 150°F	Clean	1 to 4 months
1000 RPM	-20°F - 200°F	Clean	1 week to 1 month
1500 RPM	-20°F - 200°F	Clean	Bi-weekly
1500 to Max. Catalog Rating	Up to 150°F 150° - 200°F -20°F - 200°F -20°F - 200°F	Dirty Dirty Very Dirty Extreme Conditions	Daily to 1 week Daily to 1 week Daily to 1 week Daily to 1 week

Table 5 Ball Bearing Grease Charge

Shaft Size (Inches)	Grease Charge (Ounces)
1/2 to 1	0.03
1 1/16 to 1 3/16	0.10
1 1/4 to 1 1/2	0.15
1 11/16 to 1 15/16	0.20
2 to 2 7/16	0.30
2 1/2 to 2 15/16	0.50
3 to 3 7/16	0.85
3 1/2 to 4	1.50

Table 6 Roller Bearing Relubrication

Speed	Temperature	Cleanliness	Greasing Intervals
100 RPM	-20°F - 125°F	Clean	6 months
500 RPM	-20°F - 150°F	Clean	2 months
1000 RPM	-20°F - 210°F	Clean	2 weeks
1500 to Max. Catalog Rating	-20°F - 150°F 150° - 200°F -20°F - 200°F -20°F - 200°F	Dirty Dirty Very Dirty Extreme Conditions	Daily to 1 week Daily to 1 week Daily to 1 week Daily to 1 week

Table 7 Roller Bearing Grease Charge

Shaft Size (Inches)	Grease Charge (Ounces)
1 3/16 to 1 1/4	0.10
1 3/8 to 1 7/16	0.22
1 1/2 to 1 11/16	0.32
1 3/4 to 2	0.50
2 to 2 3/16	0.55
2 1/4 to 2 1/2	0.65
2 11/16 to 3	0.85
3 3/16 to 3 1/2	1.25
3 15/16 to 4	2.50
4 7/16 to 4 1/2	3.10

These charts are general recommendations. Experience and testing may be required for specific applications.

Air Handling Interchange

Table 8 Set Screw Ball Bearing Interchange

Requested Part Description	Manufacturer	Browning Part Description
P2BSCAH	Dodge*	VPS-2XX AH
P2BSCMAH	Dodge*	VPS-3XX AH
SYXX-TF/AH	SKF*	VPS-2XX AH
SYMXX-TF/AH	SKF*	VPS-3XX AH
RASC	Fafnir*	VPS-2XX AH
P3-UXXN	Link-Belt*	VPS-2XX AH

Table 9 Ball Bearing Interchange (BOA)

Requested Part Description	Manufacturer	Browning Part Description
P2BDLAH	Dodge*	VPB-2XX AH
P2BDLMAH	Dodge*	VPB-3XX AH

Table 10 Rubber Mount Interchange

Requested Part Description	Manufacturer	Browning Part Description
R-X-FM	SKF*	RUBRE-1XX
RSCM-XX	Fafnir*	RUBRE-1XX

Table 11 Roller Bearing Interchange

Requested Part Description	Manufacturer	Browning Part Description
ZEP-2XXX	Rexnord™	SPB1000
SYR XX	SKF™	SPB1000
PE-B224XXH	Link-Belt™	SPB1000

* Always consult manufacturer's catalog for detailed dimensions.

*Dodge is a trademark of Reliance Electric Company. *SKF is a trademark of SKF USA Inc. *Fafnir is a trademark of the Torrington Company. *Link-Belt is a trademark of Rexnord Corp. *Rexnord is a trademark of Rexnord Industries Inc. These trade names, trademarks and/or registered trademarks of others are used herein for product comparison purposes only, are the property of their respective owners and are not owned or controlled by Emerson Power Transmission Corporation. Emerson Power Transmission does not represent or warrant the accuracy of this document.

Visit our online resources at...

www.Emerson-ept.com

Visit our website for a full suite of installation instructions, product interchange software and our e-catalog to name a few.



www.Facebook.com/BrowningBeltDrives

Like us on Facebook and be the first to view all the Belt Drive Monthly's



www.Linkedin.com

Search Browning® Belt Drives Save the Green®

Join in on our belt drive conversations for energy savings and benefits



www.YouTube.com/thepowertransmission

Subscribe and be the first to know when new videos are posted

Check out our Save the Green Video while you are there



It's Free... Download the Browning Energy Efficiency Calculator for your iPhone or iPod Touch. Visit the iTunes Store and Search "Browning V-belts"

Notes

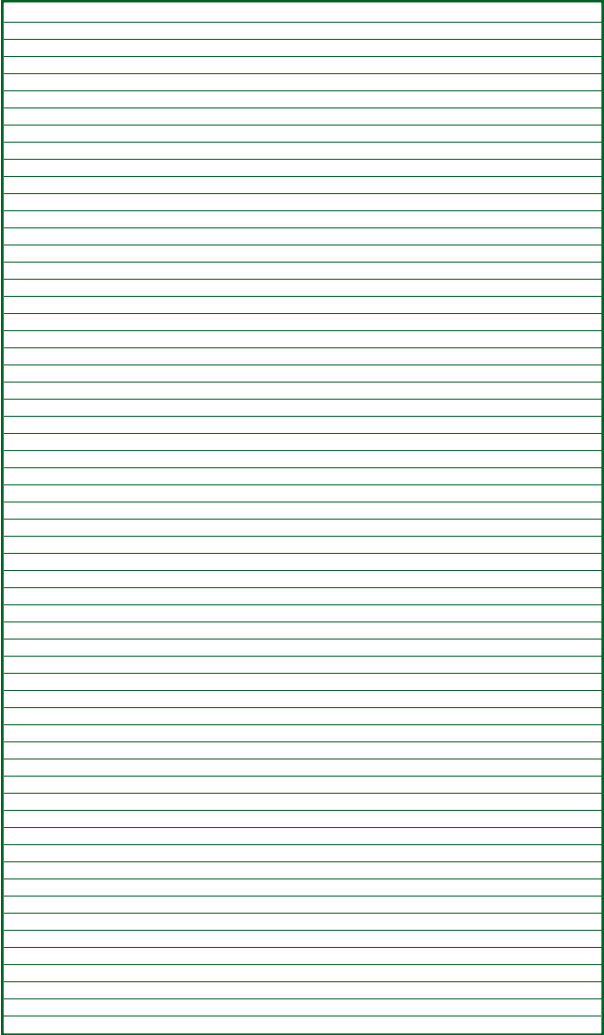

A large rectangular box with a green border, containing horizontal lines for writing notes. The box is empty and spans most of the page width and height.

APPLICATION CONSIDERATIONS

The proper selection and application of power transmission products and components, including the related area of product safety, is the responsibility of the customer. Operating and performance requirements and potential associated issues will vary appreciably depending upon the use and application of such products and components. The scope of the technical and application information included in this publication is necessarily limited. Unusual operating environments and conditions, lubrication requirements, loading supports, and other factors can materially affect the application and operating results of the products and components and the customer should carefully review its requirements. Any technical advice or review furnished by Emerson Power Transmission Corporation and its divisions with respect to the use of products and components is given in good faith and without charge, and Emerson assumes no obligation or liability for the advice given, or results obtained, all such advice and review being given and accepted at customer's risk.

For a copy of our **Standard Terms and Conditions of Sale, Disclaimers of Warranty, Limitation of Liability and Remedy**, please contact Emerson Power Transmission Customer Service at 1-866-869-2075. These terms and conditions of sale, disclaimers and limitations of liability apply to any person who may buy, acquire or use an Emerson Power Transmission Corporation product referred to herein, including any person who buys from a licensed distributor of these branded products.

Browning[®]

The First Name in Performance HVAC Belt Drives and Bearing Products

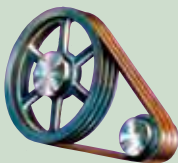

Customer Service — U.S. and International

Phone 866 869 2075

Fax 606 564 2052

Customer Service — Canada

Phone 905 294 9330

800 268 4149

Fax 800 668 9005

Application Engineering

Phone 800 626 2093

www.emerson-ept.com

MCC10005
Form #8932
Printed in U.S.